

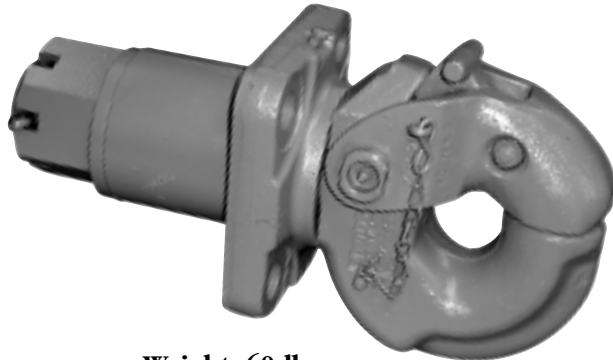

PH-775-01552

PH-775-01552

SPECIFICATIONS



Weight: 60 lbs.

IMPORTANT SAFETY INFORMATION:

Maintain adequate vertical (tongue) load to properly control the trailer (generally 10%) but do not exceed the above rated capacities.

DO NOT damage the latch. Be particularly careful with the drawbar when coupling and uncoupling.

Other steps and inspections are also required. Consult OSHA and D.O.T. regulations and American Trucking Association for complete coupling and uncoupling procedures. These cover items such as cargo securement, brakes, lights, safety chains, and other important requirements.

This equipment must not be used or maintained in a careless manner.

GENERAL INFORMATION:

1. Do not modify or add to the product.
2. Wear safety goggles during installation, removal and servicing.
3. Never strike any part of the item with a steel hammer.
4. Do not weld on this product.

This product is covered by SAF-HOLLAND's Commercial Products Warranty. SAF-HOLLAND reserves the right, without giving prior notice, to change specifications and dimensions as designs are altered or improved.

TOWING APPLICATIONS:

For general over-the-road towing as well as highway doubles. Use **ONLY** in conjunction with a non-swivel type drawbar. For off-road applications, reduce the capacities above by 25%.

DRAWBAR EYE DIMENSIONS:

3" I.D. with 1.63" diameter section.

MOUNTING:

1. Use a mounting structure of sufficient strength to support the rated capacity of the pintle hook in accordance with SAE J849 and SAE J847 respectively.

Swivel type pintle hook. Swivel action provides torsional relief at the coupling.

20,000 lbs. Maximum Vertical Load

100,000 lbs. Maximum Gross Trailer Weight

2. Use the hole pattern described on the reverse.
3. Use (4) .88" grade 8 fasteners, properly tightened. The recommended minimum torque is 300 ft-lbs when using a nut and bolt, and 350 ft-lbs when using bolts only — per SAE J429.
4. The rear nut (XA-780-1) should be tightened to 100 ft-lbs torque, then backed off as required, to insert the cotter pin (XB-781-1) in the shank. Install and spread the cotter pin.

OPERATING INSTRUCTIONS:

1. Before operating, inspect for proper operation, worn, damaged or missing parts and secure mounting. Correct as required before use.
2. Make sure the pintle is in the proper coupling position as shown above (with the latch on the top).
3. Open latch (XA-764-5A) by removing the cotter pin (XA-199-A) and the lifting lock (A).
4. Position the drawbar eye over the horn of the pintle and lower into place.
5. Push the latch closed and insert the cotter pin. Spread the cotter pin.

MAINTENANCE:

For proper performance, the following maintenance steps should be performed every 30,000 miles or 3 months, whichever comes first.

1. Clean and check for proper operation. Inspect for worn, damaged or missing parts. Replace as required using only SAF-HOLLAND Original parts.
2. Inspect, in particular, the coupling contact area and periodically disassemble to inspect for wear on the shank and mounting housing. Replace any component when wear exceeds 1/8" (0.125") from the original surface profile.
3. Regularly lubricate the latch pivots through the grease zerk in the latch. Apply a small quantity of grease through the grease zerk in the latch. Apply a small quantity of grease through the grease zerk in the mounting housing.
4. Check mounting fasteners for proper torque. Retighten nut (XA-780-1) as instructed in Step 4, "Mounting", above.

PH-775-01552

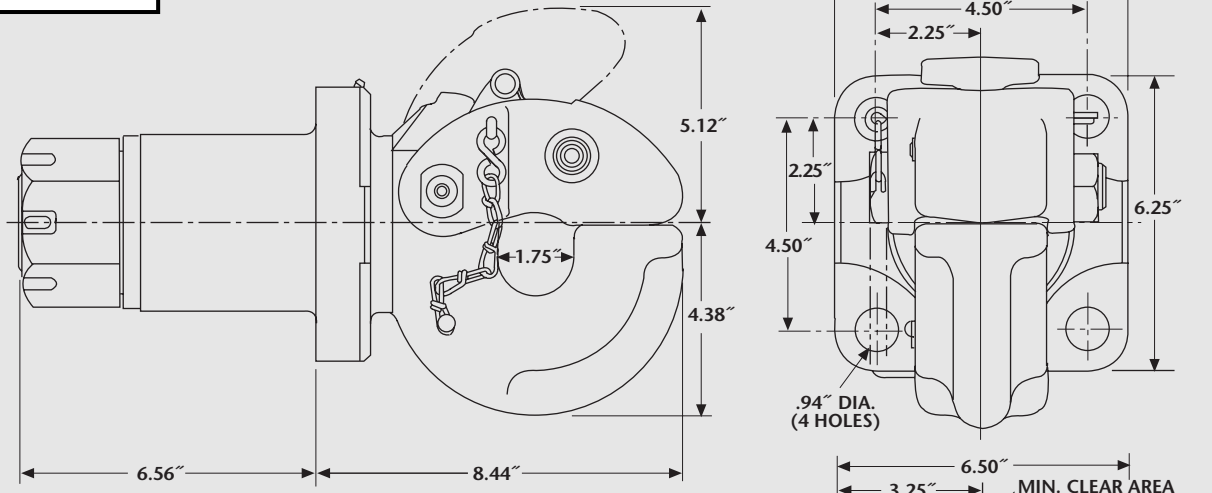

ALL DIMENSIONS SHOWN ARE NOMINAL

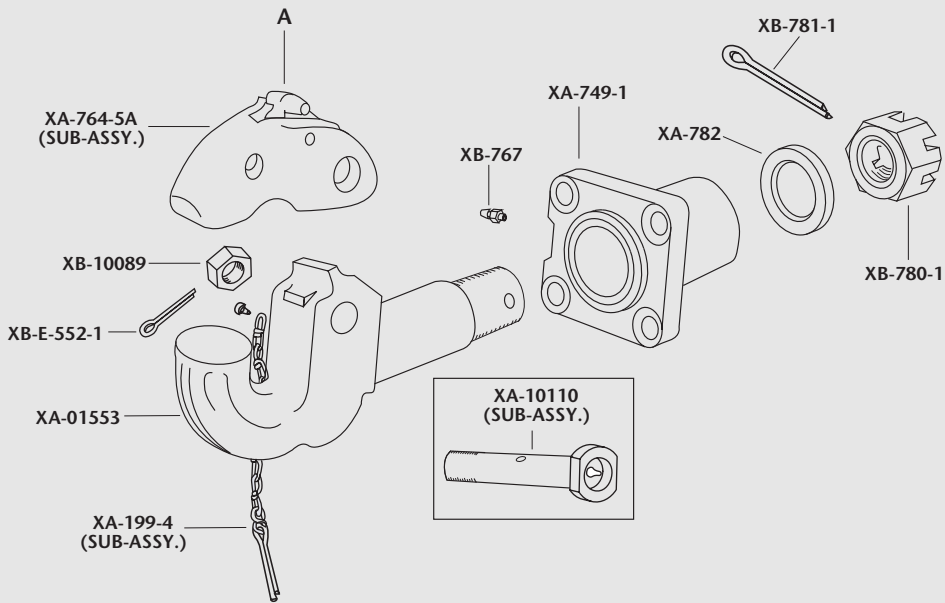
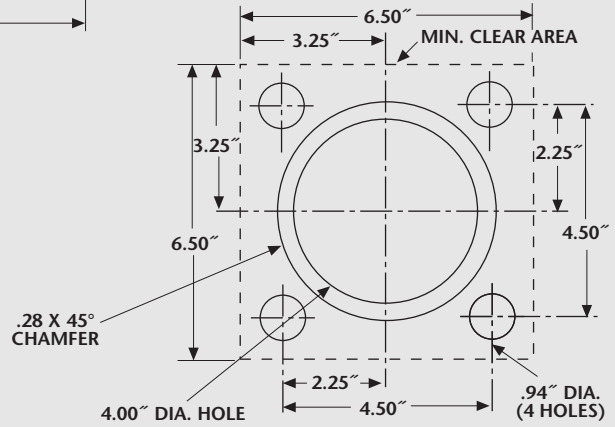

SAF-HOLLAND USA, Inc.
888.396.6501 Fax 800.356.3929

SAF-HOLLAND Canada Limited
519.537.3494 Fax 800.565.7753
Western Canada
604.574.7491 Fax 604.574.0244