



BH-50

BH-50 SPECIFICATIONS



Weight: 135 lbs.



5" diameter ball and socket assembly. Provides a positive, no-slack fit with oscillation up to 30 degrees in all directions. A top mounted adjustment ratchet provides for easier coupling, uncoupling, and slack adjustment.

**8,000 lbs. Maximum Vertical Load
80,000 lbs. Maximum Gross Trailer Weight**



WARNING

Maintain adequate vertical (tongue) load to properly control the trailer (generally 10%), but do not exceed the above rated capacities.

TOWING APPLICATIONS:

Trailer applications which combine on- and off-road service, especially where a hinge-tongued drawbar is used, and when a tow vehicle and trailer are not frequently uncoupled. Ideal for log haulers, gravel trailers, liquid bulk trailers, and grain trailers.

MOUNTING:

1. Use a mounting structure of sufficient strength to support the rated capacity of the ball hitch in accordance with SAE J849 and SAE J847, respectively.
2. Attach the hitch ball socket to the mounting structure by welding as specified on page 3. These weld specifications are required to develop sufficient hitch strength.



WARNING

When welding, use a procedure which assures a sound, good quality weld, and which protects the operator and others. Overwelding may cause distortion and damage. Underwelding may

not develop sufficient strength. A low hydrogen process and E70XX filler metal are recommended. Take precautions to insure that the tractor's electrical system is not damaged by the welding.

3. Mount the ball to its mounting structure using (4) 1" grade 8 fasteners, properly tightened.

OPERATING INSTRUCTIONS:

1. Before operating, inspect for proper operation; worn, damaged, or missing parts; and a secure mounting. Correct as required before use.
2. Remove safety pin (C), pull back on the arm (A) and turn the handle (B) counterclockwise all the way to open up the socket for coupling.
3. Position the socket on the ball and seat the socket on the ball.



WARNING

Other steps and inspections are also required. Consult OSHA and D.O.T. regulations and American Trucking Association for complete coupling and uncoupling procedures. These cover items such as cargo securement, brakes, lights, safety chains, and other important requirements.

4. Turn arm (A) clockwise until tight to take up slack. Back off one notch.
5. Check the fit of the ball and socket. Adjust and retighten if necessary.
6. Insert the safety pin (C) into the hole provided in arm (A), and into tab (D) on the ball socket.

MAINTENANCE

The ball hitch assembly is designed to be operated within 30° articulation, and is not designed to be jackknifed. Exceeding the articulation limits, or jackknifing the two units in excess of 90°, can result in damage to the ball hitch assembly.

Therefore, as part of your regular preventive maintenance program, inspect both the ball assembly (*ITEM 1*) and the coupler assembly (*ITEM 2*) for any indication of limited articulation and/or jackknifing. These marks will most likely appear around the outer edges of the ball assembly platform, or on the coupler tongue (see *FIGURE 1*).

This inspection should be conducted every 3 months, or 30,000 miles, or sooner if over-articulation is possible in your application.



If during operation, jackknifing or over-articulation is suspected, the integrity of the ball assembly must be verified — as outlined below — before further use.

Inspect the ball and coupler in the areas indicated in *FIGURE 2*. If, upon inspection, burrs and indications of limited articulation are discovered, the following procedures are recommended:

1. Do what you can to eliminate it from happening again (change your route, system design, driver training, etc.).
2. Verify the integrity of the ball and coupler assembly using either dye penetrant or magnetic particle inspection. Inspect the areas shown in *FIGURE 2*.

FIGURE 1

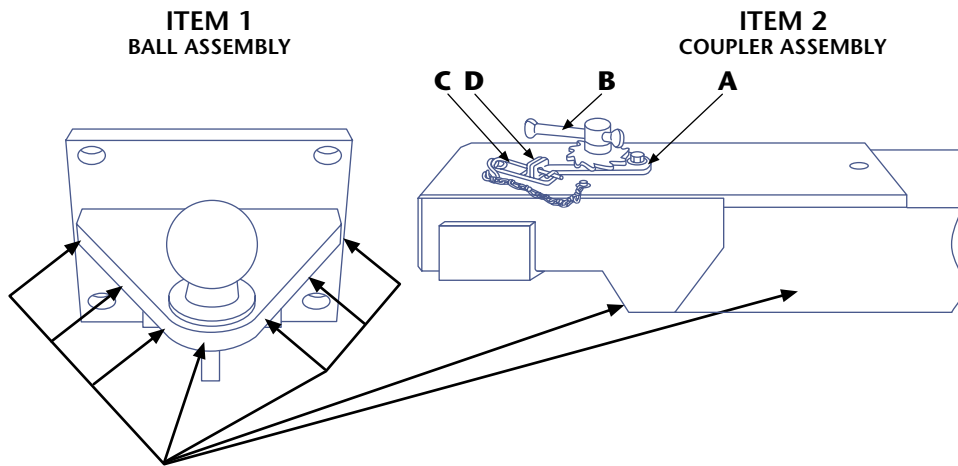

Inspect these areas for marks and burrs indicating jackknife or lack of articulation.

FIGURE 2

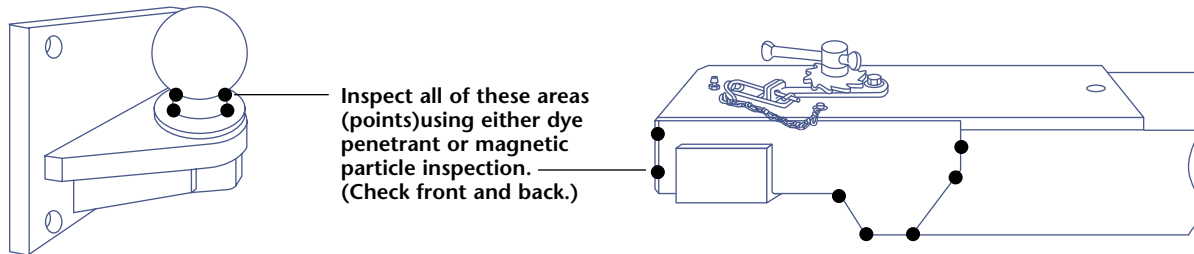

BH-50

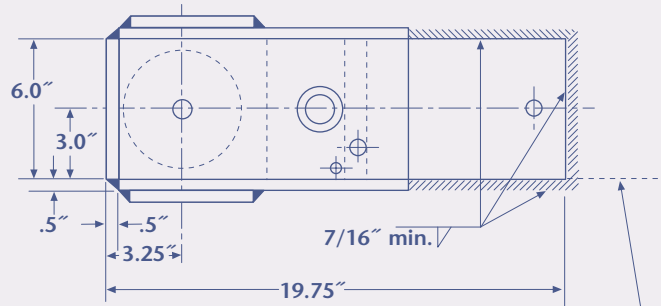
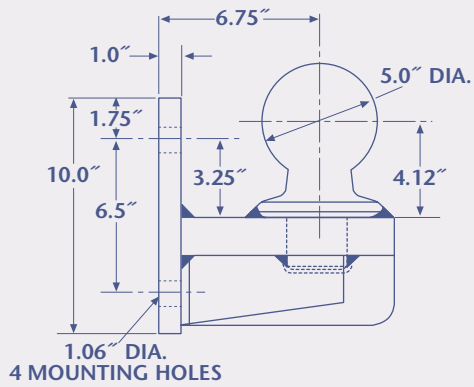
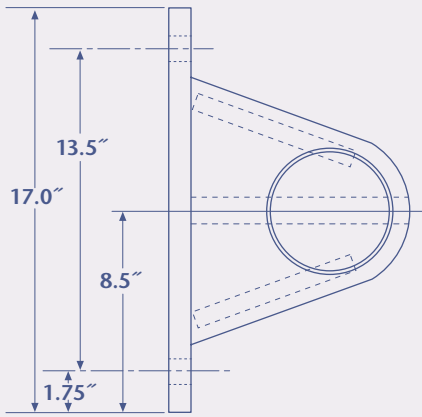

NOTE: A minimum of 35 lineal inches of weld of the size noted is required to develop sufficient hitch strength. TONGUE STRUCTURE

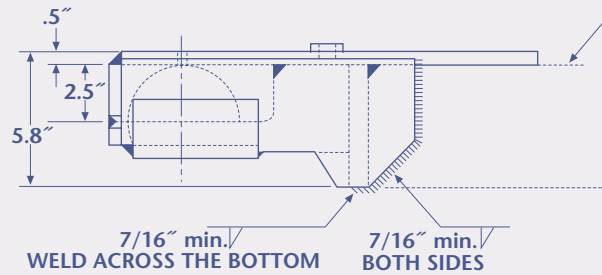

ALL DIMENSIONS SHOWN ARE NOMINAL

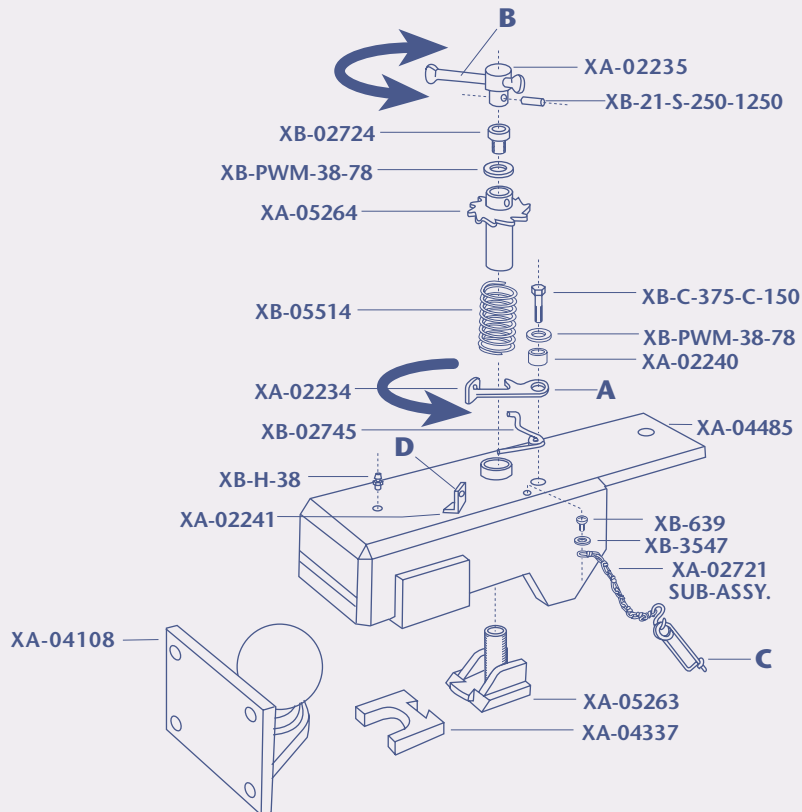

SAFETY CHAIN/CABLE USE

A safety chain/cable system is required by federal, state, and provincial law when using a Holland ball hitch assembly. The system must have the following requirements:

1. Cannot be attached to the ball/coupler drawbar arrangement.
2. The system must have no more slack than is necessary to permit the vehicles to turn properly.
3. The system, and its attachments, must have an ultimate strength of not less than the gross weight of the vehicles or the vehicles being towed.
4. The system must be connected in a manner which prevents the tow bar from dropping to the ground in the event that it fails or becomes disconnected.
5. The system must have two (2) attachment points on the towed vehicle, which are as far apart as the configuration of the frame or axle permits.
6. When two safety chains or cables are used and attached to the towing vehicle at separate points, the points of attachment must be located equally distant from — and on opposite sides of — the centerline of the towing vehicle.

SAFETY CHAIN/CABLE INSPECTION

Inspection of the safety chain/cable system should be conducted in conjunction with the ball and coupler inspection — every 3 months, or 30,000 miles.

The inspection should confirm conformance to the above requirements. Any worn or frayed component which would reduce the system's strength should be replaced.

GENERAL INFORMATION:

1. Do not modify or add to the product.
2. Wear safety goggles during installation, removal, and servicing.
3. Never strike any part of the item with a steel hammer.
4. Do not weld on this product, other than as directed for installation, without written consent from the factory.

This product is covered by Holland's Commercial Products Warranty. Holland reserves the right, without giving prior notice, to change specifications and dimensions as designs are altered or improved.



This product must not be used or maintained in a careless manner.



Holland Hitch Company Divisions:

Holland, MI
Whitehouse Station, NJ
Denmark, SC
Wylie, TX
Milpitas, CA
Phone: 888-396-6501
Fax: 800-769-3299

Holland Binkley Co.

Warrenton, MO
Phone: 636-456-3455
Fax: 636-456-6792

Holland Binkley Co. Axle Products Division

Delphos, OH
Phone: 419-692-6015
Fax: 419-692-0503

Holland Neway International, Inc.

Muskegon, MI
Phone: 231-773-3271
Fax: 231-766-3893

Holland International, Inc.

Holland, MI
Phone: 616-396-6501
Fax: 616-396-1511

Holland Hitch of Canada, Ltd.

Woodstock, Ontario • Canada
Phone: 519-537-3494
Fax: 800-565-7753

Holland Hitch Western, Ltd.

Surrey, British Columbia • Canada
Phone: 604-574-7491
Fax: 604-574-0244

Holland Equipment, Ltd.

Norwich, Ontario • Canada
Phone: 519-863-3414
Fax: 519-863-2398

Copyright © May 2001 • The Holland Group, Inc.