

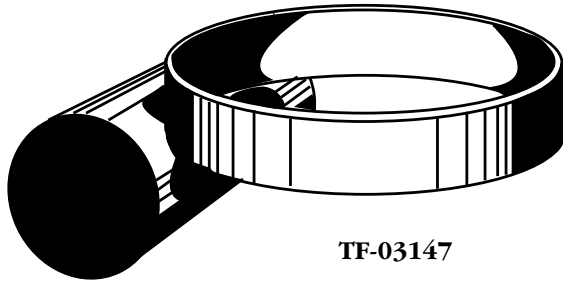

COUPLER PRODUCTS

PH-200, PH-300, PH-400, & PH-550 INFORMATION



TF-03147

Plunger adjustment procedures for PH-200, PH-300, PH-400, and PH-550 Series Pintle Hooks Using TF-03147 Adjustment Gage

1. Place tool, TF-03147, over horn of pintle hook as shown in Figure 1.
2. Energize plunger air cylinder.



WARNING

Keep hands and fingers clear.

3. Adjust air cylinder so plunger just contacts adjustment tool and the tool will not move when rotated or twisted by hand (see Figure 1).

NOTE: Be sure the cylinder rod and plunger rod have .63" minimum thread engagement. (Factory set engagement is approximately 1.63")

4. Tighten cylinder rod lock nut securely.
5. De-energize the air cylinder.
6. Remove adjustment gage (TF-03147).
7. Verify that the plunger retracts far enough to allow the drawbar to be set down over the horn properly.

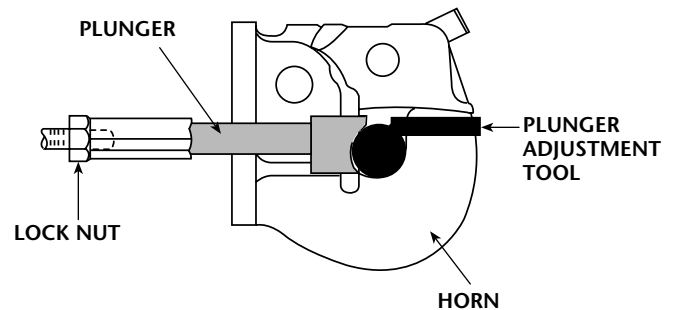

Figure 1



Holland Hitch Company Divisions:

Holland, MI
Whitehouse Station, NJ
Denmark, SC
Wylie, TX
Milpitas, CA
Phone: 888-396-6501
Fax: 800-769-3299

Holland Binkley Co.

Warrenton, MO
Phone: 636-456-3455
Fax: 636-456-6792

Holland Binkley Co. Axle Products Division

Delphos, OH
Phone: 419-692-6015
Fax: 419-692-0503

Holland Neway International, Inc.

Muskegon, MI
Phone: 231-773-3271
Fax: 231-766-3893

Holland International, Inc.

Holland, MI
Phone: 616-396-6501
Fax: 616-396-1511

Holland Hitch of Canada, Ltd.

Woodstock, Ontario • Canada
Phone: 519-537-3494
Fax: 800-565-7753

Holland Hitch Western, Ltd.

Surrey, British Columbia • Canada
Phone: 604-574-7491
Fax: 604-574-0244

Holland Equipment, Ltd.

Norwich, Ontario • Canada
Phone: 519-863-3414
Fax: 519-863-2398

Copyright © February 2001 • The Holland Group, Inc.