

COUPLER PRODUCTS

LATCH REPLACEMENT PROCEDURES

(PH-300 shown)



RK-02536

For PH-200, PH-300, PH-400, and PH-400-H

RK-03179

For PH-200-R and PH-300-R (reverse handle)

1. Remove nut, pivot bolt, washer and latch (discard nut).

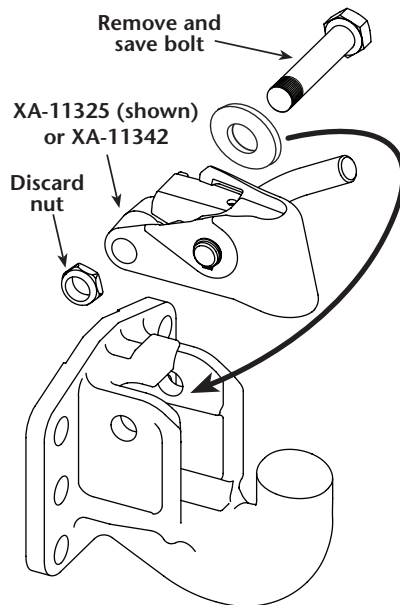

2. Clean and apply Never-Seez[®] to entire shaft of pivot bolt (not on threads).

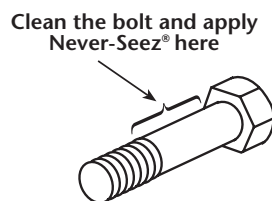

3. Install the new latch using existing bolt, washer, and new nut – torque nut to 75-100 ft-lbs.

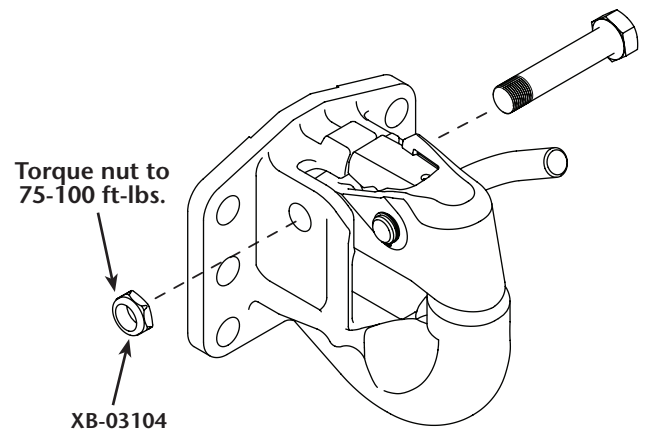

4. Check latch for proper operation. When closed, latch dog must automatically engage under lip as shown.

XA-11325 (shown)

