

Specifications

PH-775SL11

(Direct replacement for PH-775-01552)

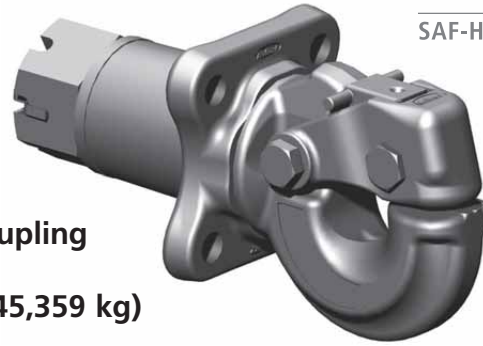

NoLube® Swivel Type Pintle Hook

- Swivel action provides torsional relief at the coupling
- Maximum Vertical Load: 20,000 lbs. (9,071 kg)
Maximum Gross Trailer Weight: 100,000 lbs. (45,359 kg)
Weight: 57 lbs.

Important Safety Information

Maintain adequate vertical (tongue) load to properly control the trailer (generally 10%) but do not exceed the above rated capacities.

DO NOT damage the latch. Be particularly careful with the drawbar when coupling and uncoupling.

Other steps and inspections are also required. Consult OSHA and D.O.T. regulations and American Trucking Association for complete coupling and uncoupling procedures. These cover items such as cargo securement, brakes, lights, safety chains, and other important requirements.

This equipment must not be used or maintained in a careless manner.

General Information

1. Do not modify or add to the product.
2. Wear safety goggles during installation, removal and servicing.
3. Never strike any part of the item with a steel hammer.
4. Do not weld on this product.

This product is covered by SAF-HOLLAND's Commercial Products Warranty. SAF-HOLLAND reserves the right, without giving prior notice, to change specifications and dimensions as designs are altered or improved.

Towing Applications

For general over-the-road towing as well as highway doubles. Use ONLY in conjunction with a non-swivel type drawbar. For off-road applications, reduce the capacities above by 25%.

Drawbar Eye Dimensions

DO NOT use with a flat, square or rectangular cross-section drawbar. Use a 3" ID round drawbar with 1.63" diameter section.

Mounting

1. Use a mounting structure of sufficient strength to support the rated capacity of the pintle hook in accordance with SAE J849 and SAE J847.
2. Use the hole pattern described on the reverse.
3. Use (4) .88" Grade 8 fasteners, properly tightened. The recommended minimum torque is 300 ft-lbs when using a nut and bolt and 350 ft-lbs when using bolts only. (Reference: SAE J429.)
4. The rear nut (XA-780-1) should be tightened to 100 ft-lbs torque and then backed off a maximum of 1/6 of a full turn to align the recesses in the castellated nut with the hole in the shank. Insert the cotter pin (XB-781-1) through the nut and shank, and then spread the ends of the cotter pin.

Operating Instructions

1. Before operating, inspect for proper operation, worn, damaged or missing parts and a secure mounting. Correct as required before use.
2. Make sure the pintle is in the proper coupling position as shown at right (with the latch on top).
3. Open the latch (XA-10545-1) by lifting the lock handle (A).
4. Position the drawbar eye over the horn of the pintle and lower into place.
5. Push the latch closed. When locked, the lock handle (A) will rotate and move up until it is flush with the top of the latch (see illustrations at right).

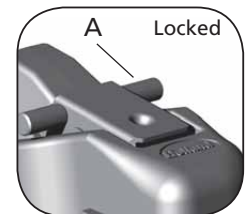

CORRECT

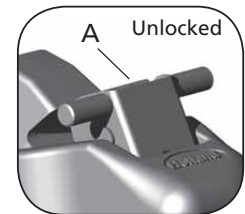

INCORRECT

Maintenance

For proper performance the following maintenance steps should be performed every 30,000 miles or 3 months, whichever comes first.

1. Clean with compressed air or water only. Inspect for worn, damaged or missing parts. Replace as required using only Holland parts.
2. Inspect the pintle hook (XA-10517-1) and latch (XA-10545-1 sub-assembly) in the areas where contact is made with the drawbar for excessive wear. Replace the hook when wear exceeds 3/16" (0.188") from the original surface profile.
3. With the latch closed, measure the gap between the hook and the latch while lifting up on the latch. Replace the latch when the gap exceeds 3/8" (0.375"). See Detail A on page 2.
4. Check the pintle hook for horizontal play along the axis of the housing (push/pull) and measure the gap between the housing and the flange face. When the gap exceeds 0.04", remove the cotter pin and tighten the nut (XA-780-1) 1/6 of a full turn then reinstall the cotter pin. Verify the pintle hook will rotate freely. See Detail B on page 2.
5. Check the pintle hook for vertical play within the housing. When up and down play exceeds 1/8" (0.125"), the housing should be unbolted from its mounting structure and turned 180 degrees and remounted. When up and down play exceeds 1/4" (0.25"), the housing should be replaced.
6. Check mounting fasteners as instructed in Step 3 of the "Mounting" section listed on page 1.



SAF-HOLLAND Group

PH-775SL11 Pintle Hook

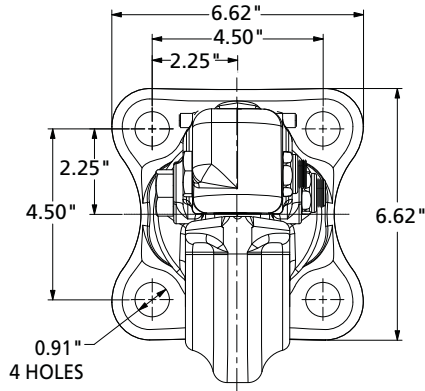
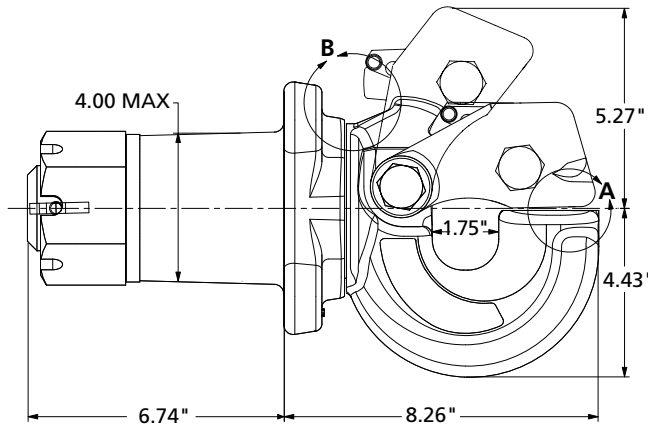

DETAIL A

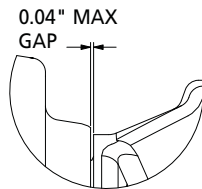

DETAIL B

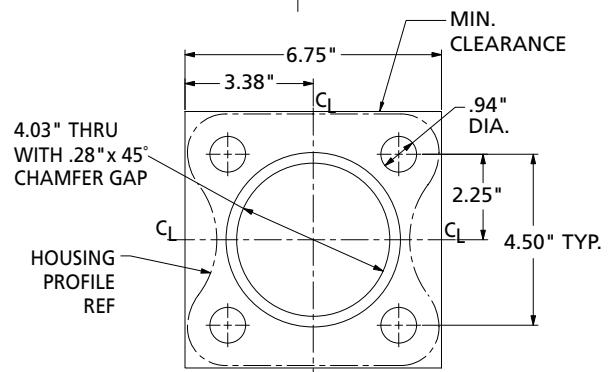

REQUIRED MOUNTING INTERFACE

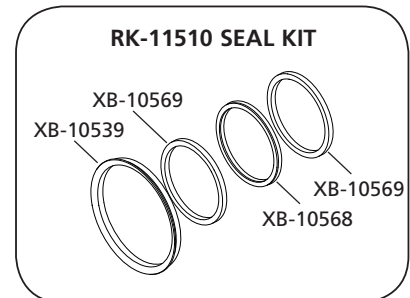
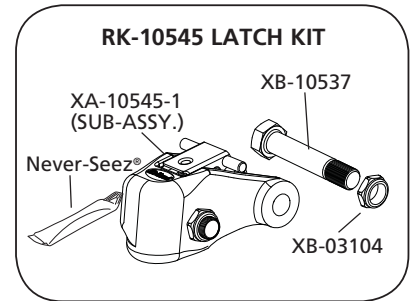
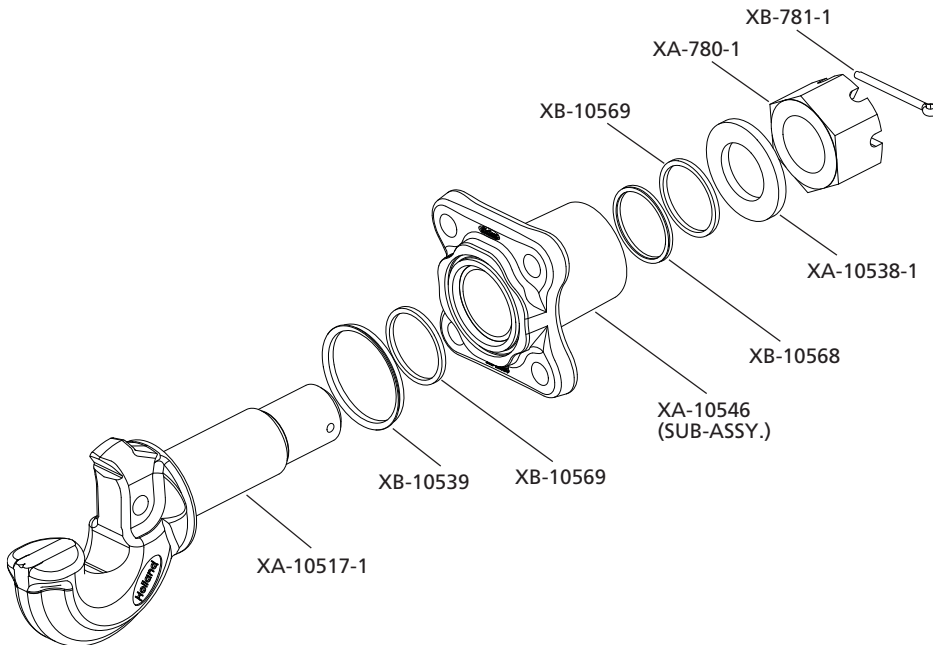

ALL DIMENSIONS SHOWN ARE NOMINAL

Turn over for Spanish

XL-PH334-01-ES Rev D - 2011-02-24 - Amendments and errors reserved. © SAF-HOLLAND, Inc.

