



COUPLER PRODUCTS

LATCH REPLACEMENT PROCEDURE



RK-10632-1

**For PH-10RP51, PH-30SA51,
PH-30SB51 and PH-30RP51 Pintle Hooks
With a Pin and Lanyard**

VERIFY KIT CONTENTS

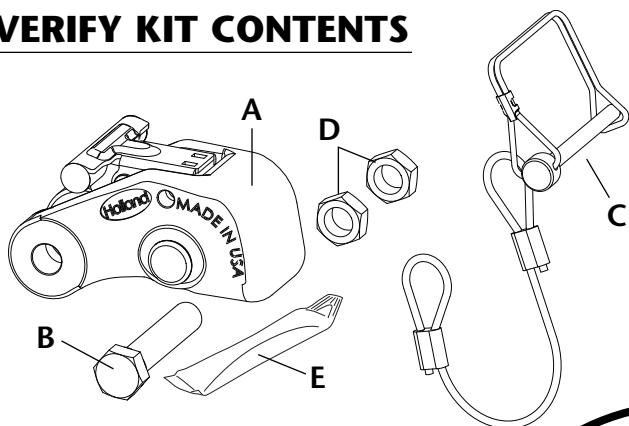

Kit Contains:

ITEM	PART NO.	QTY
A	XA-10632-1	1
B	XB-T-89-4	1
C	XB-11157	1
D	XB-11048	2
E	Never-Seez®	1

Never-Seez® is a registered trademark of Bostik, Inc.

PRODUCT IDENTIFICATION

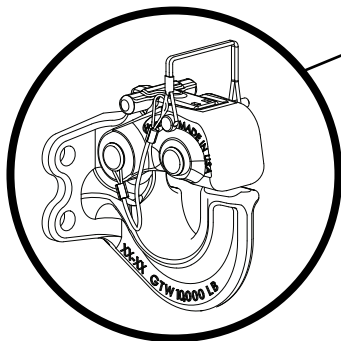
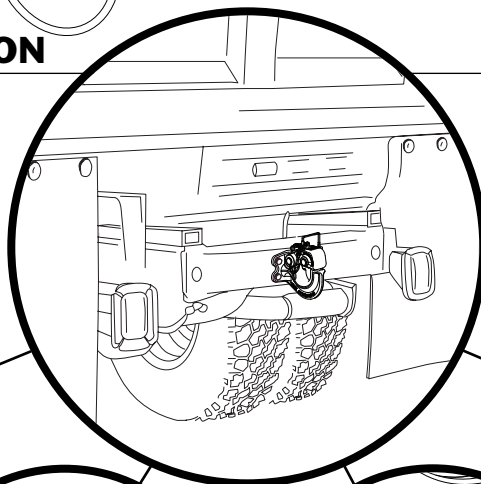

PH-10RP51 PINTLE HOOK
For additional information,
reference XL-PH370

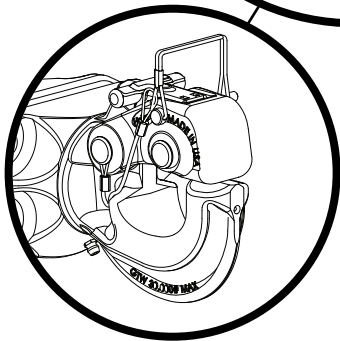

PH-30SA51 PINTLE HOOK
For additional information,
reference XL-PH369

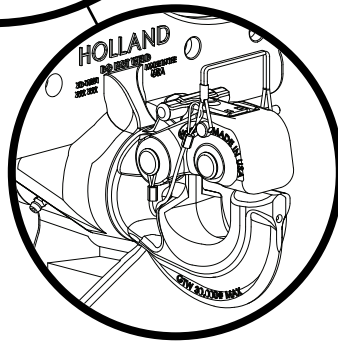

**PH-30SB51
PINTLE HOOKS**
For additional information,
reference XL-PH371

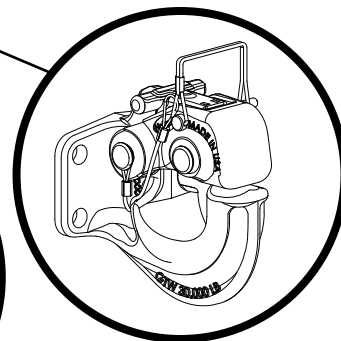

PH-30RP51 PINTLE HOOK
For additional information,
reference XL-PH364

PROCEDURE

1. Grind off head of rivet and discard rivet, latch assembly and pin and lanyard.

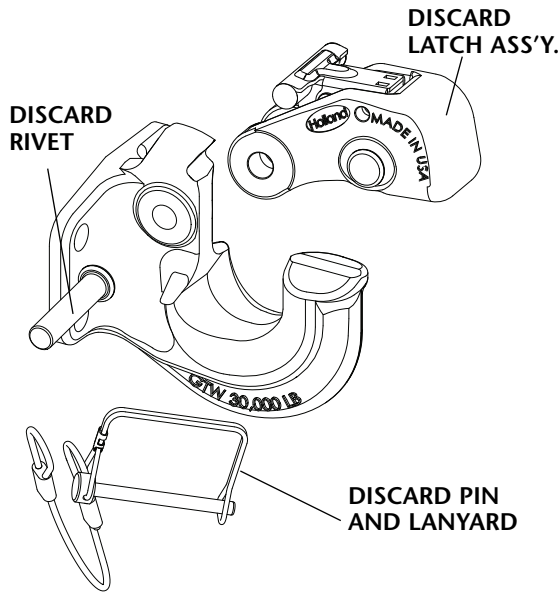

2. Apply Never-Seez® to entire shaft of the new pivot bolt (not on thread).

CLEAN THE BOLT AND APPLY NEVER-SEEZ® HERE

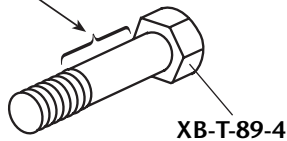

3. Install the new latch assembly using the new pivot bolt and nut. Tighten nut until it contacts the cast latch and apply an additional 1/4 turn to the nut. Visually verify that a full thread protrudes beyond the nut. If it becomes necessary to remove the lock nut, discard and use the second nut provided in the kit.

WARNING DO NOT reinstall a removed lock nut. Always install a new lock nut when removing or replacing latch assembly. A reinstalled nut may not retain properly and could result in an unintended trailer separation.

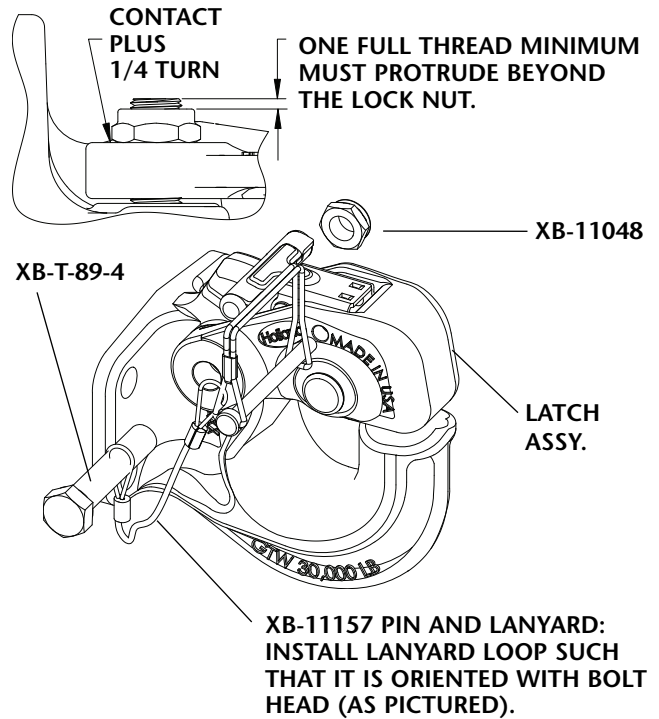

4. Check the latch for proper operation. It should open and close freely. When closed, the lock handle (A) will rotate and move down until it is flush with the top of the latch.

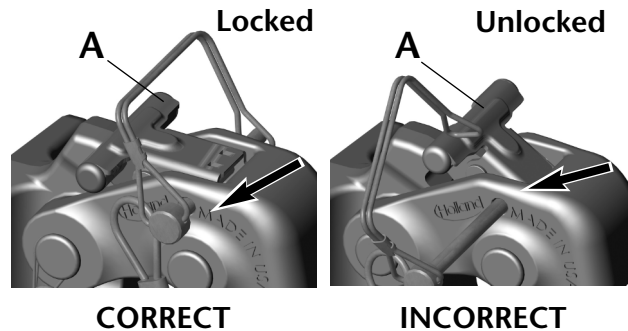

The tertiary lock pin should fit without restriction through the holes in the latch (see illustrations above).



SAF-HOLLAND USA, Inc.
888.396.6501 Fax 800.356.3929

SAF-HOLLAND Canada Limited
519.537.3494 Fax 800.565.7753
Western Canada
604.574.7491 Fax 604.574.0244

SAF-HOLLAND International, Inc.
616.396.6501 Fax 616.356.1511