



COUPLER PRODUCTS

LATCH REPLACEMENT PROCEDURE

RK-10636-1

**For the BH-200RN51 & BH-50mmRN51
Pintle Hooks (BH-200RN51 shown)**

VERIFY KIT CONTENTS

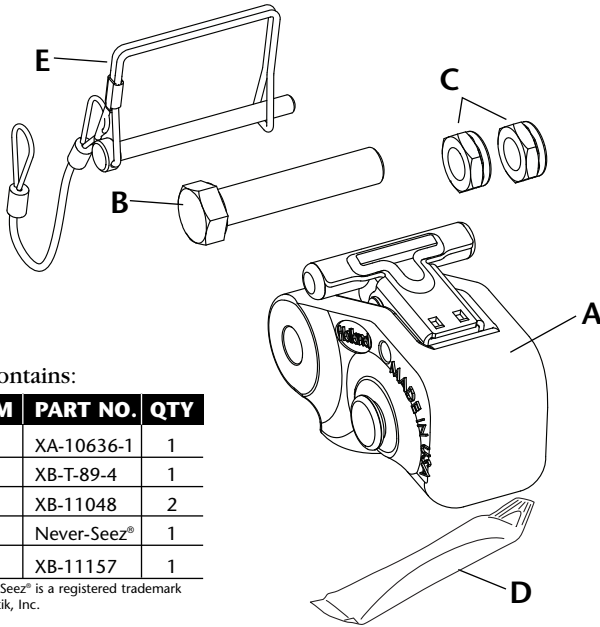

Kit contains:

ITEM	PART NO.	QTY
A	XA-10636-1	1
B	XB-T-89-4	1
C	XB-11048	2
D	Never-Seez®	1
E	XB-11157	1

Never-Seez® is a registered trademark of Bostik, Inc.

PRODUCT IDENTIFICATION

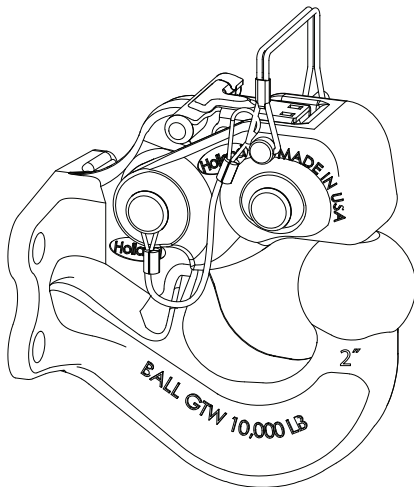

BH-200RN51 & BH-50mmRN51 PINTLE HOOKS
For additional information, reference XL-PH384 or XL-PH385.

PROCEDURE

1. Grind off head of rivet and discard rivet, latch assembly, and pin and lanyard.

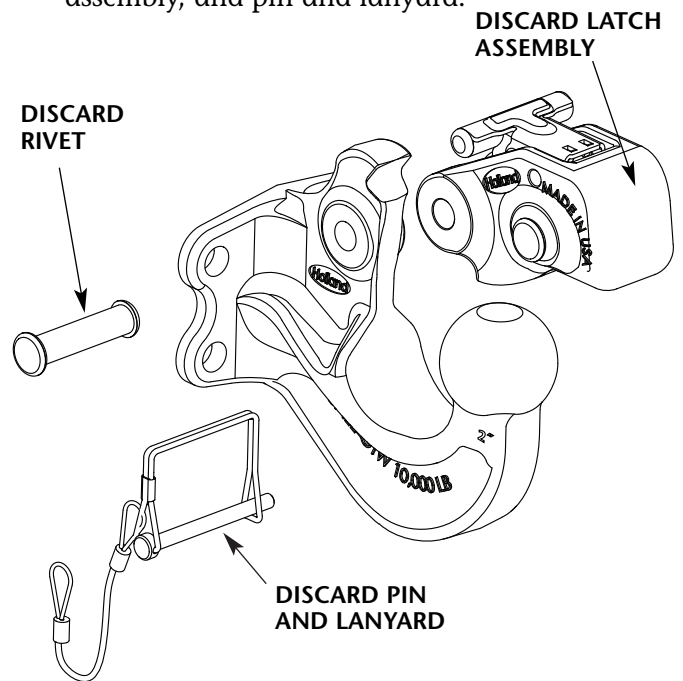

2. Apply Never-Seez® to entire shaft of the new pivot bolt (not on thread).

CLEAN THE BOLT AND APPLY NEVER-SEEZ® HERE

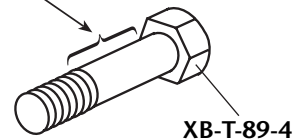

PROCEDURE *continued*

3. Install the new latch assembly using the new pivot bolt and nut. Tighten nut until it contacts the cast latch and apply an additional 1/4 turn to the nut. Visually verify that a full thread protrudes beyond the nut. If it becomes necessary to remove the lock nut, discard and use the second nut provided in the kit.

⚠ WARNING DO NOT reinstall a removed lock nut. Always install a new lock nut when removing or replacing latch assembly. A reinstalled nut may not retain properly and could result in an unintended trailer separation.

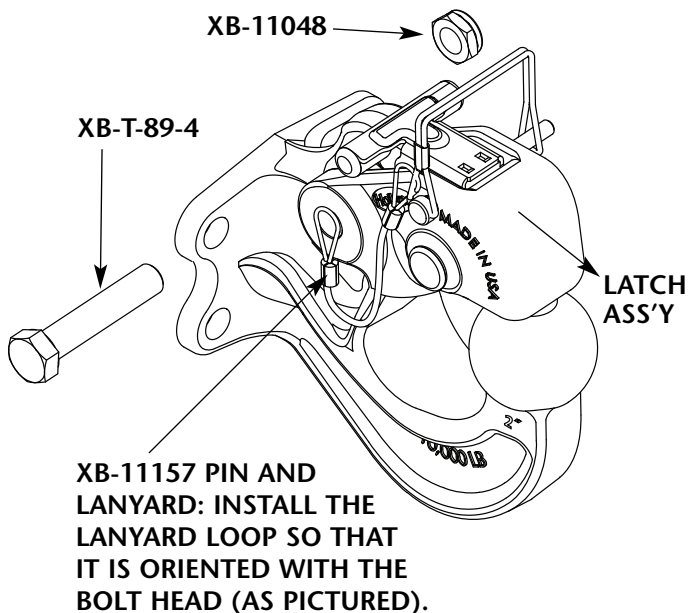
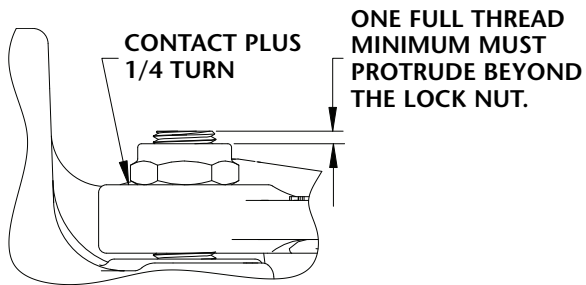

OPERATING INSTRUCTIONS

1. Before operating, inspect for proper operation, worn, damaged or missing parts and secure mounting. Correct as required before use.
2. Make sure the pintle is in the proper coupling position as shown (latch on top).
3. Open latch (A) by removing lock pin (B) and lifting the lock handle (C).
4. Position the drawbar eye over the horn of the pintle and lower into place.
5. Push the latch (A) closed and insert the lock pin (B) in the hole provided in the latch.
6. If main lock does not engage when attempting to close latch, do not force it closed by striking. Check bottom of latch and top of horn and lock seating notch on pintle body that they are free of debris.

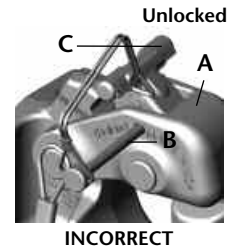
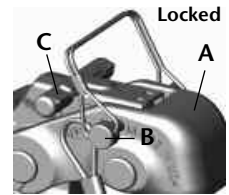

SAF-HOLLAND USA, Inc.
888.396.6501 Fax 800.356.3929

SAF-HOLLAND Canada Limited
519.537.3494 Fax 800.565.7753
Western Canada
604.574.7491 Fax 604.574.0244

SAF-HOLLAND International, Inc.
616.396.6501 Fax 616.356.1511