

Specifications Sheet

HOLLAND® Couplers



TF-675-1 DOLLY MASTER™ SPECIFICATIONS

June 2016

Introduction

The Dolly Master™ is an air-operated, truck-mounted yard-spotting assembly for positioning converter dollies.

- 390 lbs. maximum lift with 80 psi input air pressure
- 15,000 lbs. maximum drawbar pull

The Dolly Master™ is comprised of a welded steel frame and a vertical slide with integral guide ramps, on which a 1.75" diameter coupling pin is mounted. A double acting air cylinder utilizes the tractor's air supply to lower and raise the slide assembly through its 15.25" stroke. A cab control valve is also provided for inside control of Dolly Master.

Applications

Yard spotting of trailer dollies.

NOTE: The Dolly Master™ is NOT intended for use in trailer coupling or spotting.

Mounting

1. Locate the Dolly Master™ in a convenient location which does not obstruct tractor performance (cover lights, etc.) or inhibit driver visibility. Locating the unit directly in front of the driver's location may aid in alignment with dollies.
2. Locate the Dolly Master™ at an elevation that provides adequate clearance between the ground and the dolly jack when the Dolly Master™ is in the up position (**Figure 1**).
 - A. Maximum drawbar elevation range: 9"
 - B. 15.25" total stroke
 - C. Provide adequate clearance
3. If the range of drawbar heights in your fleet exceeds 9", an additional Dolly Master™, mounted at a different elevation, should be considered.
4. Use a secure mounting structure of sufficient strength to support the rated capacity of the unit. It is necessary to provide support at both the top and bottom of the unit.
5. Attach the Dolly Master™ to the mounting structure by bolting or welding (Refer to specifications).
6. A short whip guide (not supplied) can be attached to the top side of the slide to aid aligning the dolly for hookup.
7. Mount the cab control valve, then attach air lines (not supplied) as follows: Attach the tractor air supply line to the bottom port on the rear of the valve.

IMPORTANT: Use an air supply which is pressure protected (isolated) from the tractor brake system.

Connect the top port that protrudes on the right side of the valve to the lower cylinder port. Next, connect the lower valve port to the upper cylinder port. The top rear valve port should be plugged.

Operating Instructions:

1. Before operating, inspect for proper operation, worn, damaged or missing parts and a secure mounting. Correct as required before use.
2. Be sure that the Dolly Master™ is in the down position.
3. Drive slowly toward the dolly drawbar, centering it over the Dolly Master™ until the drawbar contacts the slide of the Dolly Master™.
4. Move the cab control valve to the up position, raising the slide assembly.
5. Move the cab control valve to the center position, this engages the lock.
6. Move the dolly to its desired location in the yard.
7. Lower the dolly by moving the cab control valve slowly to the down position.
8. Back away from the dolly.

IMPORTANT: Perform these procedures only with area clear of obstacles and other personnel.

Maintenance

1. Clean and check for proper operation.
2. Inspect for worn, damaged or missing parts. Replace with only SAF-HOLLAND® original parts.
3. Check for a secure mounting.
4. As required, lubricate the slide rails with a light rust-resistant oil.

IMPORTANT: This equipment MUST NOT be used or maintained in a careless manner.

Figure 1

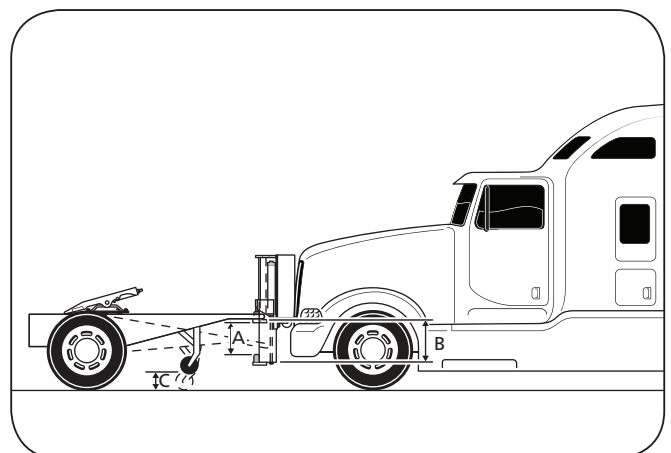

Specifications Sheet

HOLLAND® Couplers



TF-675-1 DOLLY MASTER™ SPECIFICATIONS

June 2016

General Information:

1. DO NOT modify or add to the product.
2. Wear safety goggles during installation, removal and servicing.
3. Never strike any part of the item with a steel hammer.
4. DO NOT weld on this product without written consent from the factory.

This product is covered by SAF-HOLLAND's® Commercial Products warranty. SAF-HOLLAND® reserves the right without giving prior notice, to change specifications and dimensions as designs are altered or improved.

Specifications

TF-675-1

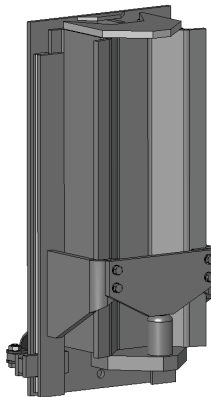

WEIGHT: 156 lbs.

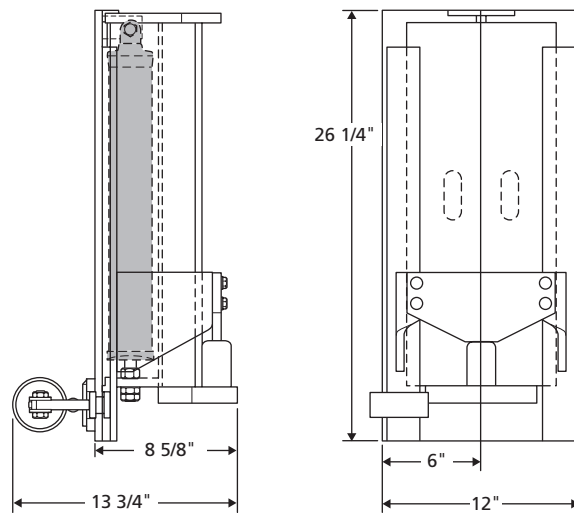

ALL DIMENSIONS SHOWN ARE NOMINAL

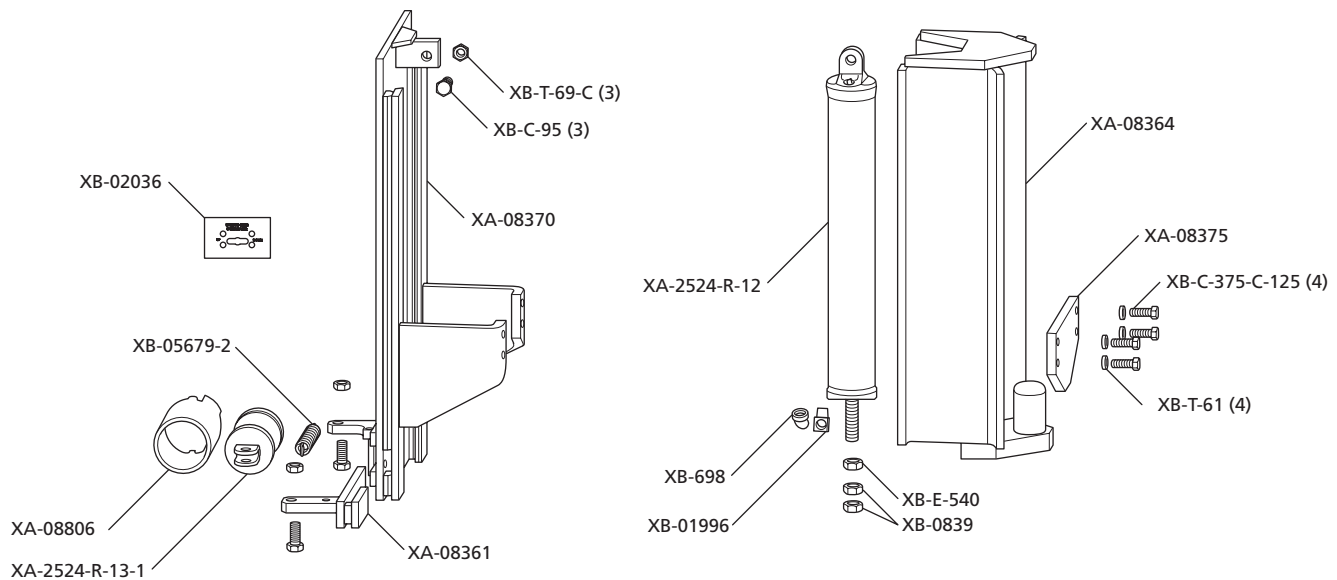

SAF-HOLLAND USA · 888.396.6501 · Fax 800.356.3929 · www.safholland.us

SAF-HOLLAND USA, INC.
1950 Industrial Blvd, Muskegon, MI 49442
www.safholland.com

