

## Trailer Air Suspension and Mechanical Suspension Air Disc Brake Product Line Update

### Product Change Notice for P89 Series Air Disc Brakes

Effective July 2016

#### Product Change:

SAF-HOLLAND is pleased to announce changes to the air disc brake product line for both trailer air suspensions and trailer mechanical suspensions. Starting July 15, 2016, the air disc brake product line will be expanded to include two (2) new models: the **NEW P89™** and **P89 PLUS™**. The INTEGRAL® Disc Brake Series with C88 and P89 wheel end configurations will be discontinued at the end of the 2017 production year. Please note, service parts for the INTEGRAL® Disc Brake Series will continue to be available even after serial production is discontinued. Both the **NEW P89** or **P89 PLUS** Air Disc Brake Systems will require new part numbers, which can be requested using electronic ordering guides on our website, or by contacting your SAF-HOLLAND sales representative.

The **NEW P89** is the base model and features heavy duty 430mm diameter vented rotors, dual piston SAF SBS 2220 K0 calipers, and a conventional wheel end assembly with premium bearings, wheel seals, and hub caps. The **NEW P89** is available on either the robust North American parallel spindle axle or a lightweight taper spindle axle. Wheel ends can be specified with conventional gear oil, synthetic oil, or semi-fluid grease. The **NEW P89** has been weight optimized and offers a 25 lb. weight savings compared to a conventional iron hub/iron drum brake configuration. The **NEW P89** Air Disc Brake is covered by a 5-year parts and labor warranty for both the disc brake and wheel end components. Please refer to the complete warranty statements available on the SAF-HOLLAND website, [www.safholland.us](http://www.safholland.us).

The **P89 PLUS** features 430mm diameter bi-metallic INTEGRAL® rotors, SAF SBS 2220 K0 calipers, long life brake chambers, and a unique long life maintenance-free bearing system. Standard on a parallel spindle axle, **P89 PLUS** provides unmatched performance and durability. The **P89 PLUS** is backed by an industry leading 7-year parts and labor warranty on the disc brake and wheel end components. Please refer to the complete warranty statements available on the SAF-HOLLAND website, [www.safholland.us](http://www.safholland.us), for details.



## Trailer Air Suspension and Mechanical Suspension Air Disc Brake Product Line Update

### Product Change Notice for P89 Series Air Disc Brakes

The **NEW P89** is available in brake ratings of 20k and 23k; the **P89 PLUS** is available in brake ratings for 20k, 23k, and 25k (refer to XL-AS20013SD Rev C for brake certification information). The **NEW P89** and **P89 PLUS** come equipped on all CBX and ULX Series suspensions.

For standard applications, both the **NEW P89** and **P89 PLUS** will use brake chambers with 3/8-18 NPT threaded ports facing away from the axle (**Figure 1**). Refer to XL-SA20022WI Rev C available on the SAF-HOLLAND website, [www.safholland.us](http://www.safholland.us), for complete details, including special configurations for yoke mount and underslung suspensions.

Figure 1

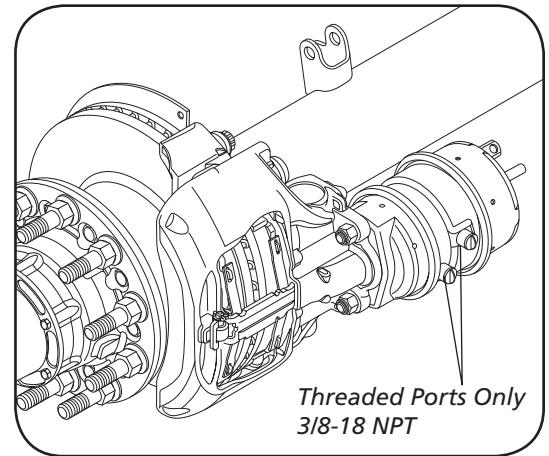

### Caliper Transition

Starting September 2016, SAF-HOLLAND will transition the INTEGRAL® disc brake models from the Knorr SK7 caliper to the SAF SBS 2220 K0 caliper. **Figure 2** provides a visual identification of the different caliper models. Service procedures for the SBS 2220 K0 caliper are provided in the XL-SA20001RM service manual, available on the SAF-HOLLAND website, [www.safholland.us](http://www.safholland.us). Please note that service components, including brake pads, are not interchangeable between caliper models.

Figure 2

