



MARK V

SERVICE BULLETIN



Installation of Mark V Landing Gear

October 17, 1994

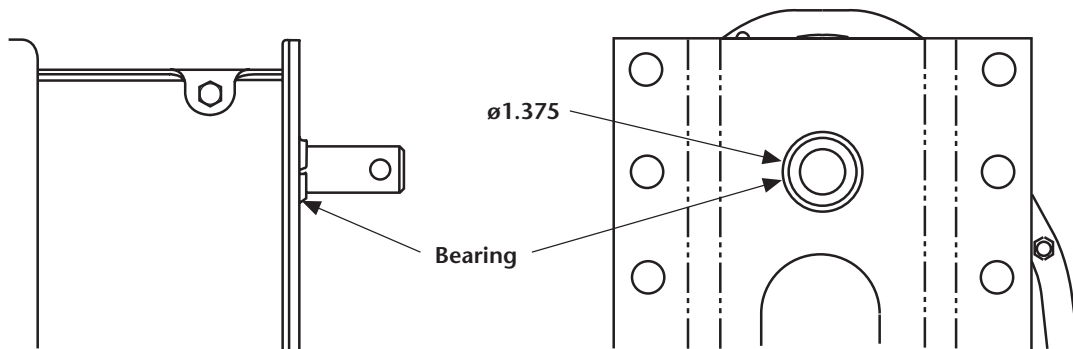

**Previous Mark V Model LG75
Manufactured Prior to May 1, 1994**

The powdered metal bearing of the redesigned Mark V has a larger diameter than the previous model Mark V. It also protrudes further past the mounting surface of the mounting plate. Special care must be taken to ensure that the bearing does not interfere with the mounting surface of the trailer and that the clearance holes for the drive shafts are large enough to provide clearance for the bushing. A minimum 1.62" diameter clearance hole is recommended. If the trailer frame is allowed to push on the bearing, binding can occur resulting in hard cranking.

IMPORTANT: Both service parts and new installations are affected by this condition. It is especially important to check for this condition when replacing older style legs with the new Mark V.

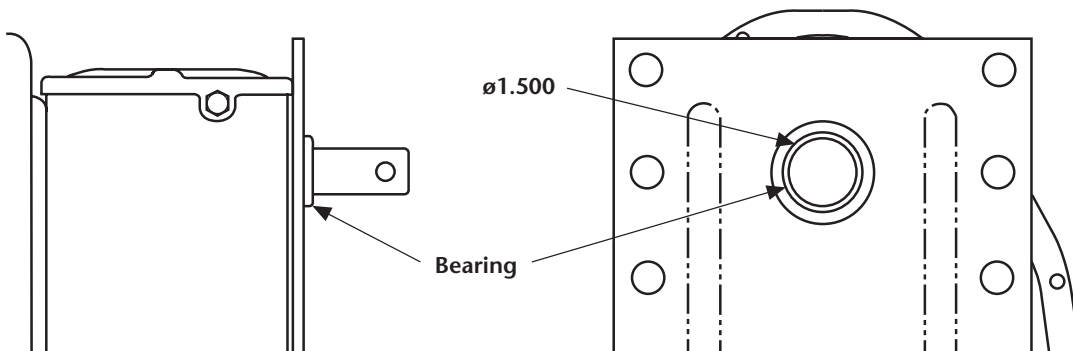

**Redesigned Mark V Model LGS
Manufactured After May 1, 1994**

Holland USA, Inc. Facilities:

Denmark, SC Muskegon, MI
Dumas, AR Warrenton, MO
Holland, MI Wylie, TX

Ph: 888-396-6501 Fax: 800-356-3929

Holland International, Inc.

Holland, MI
Phone: 616-396-6501
Fax: 616-396-1511

Holland Hitch of Canada, Ltd.

Woodstock, Ontario • Canada
Phone: 519-537-3494
Fax: 800-565-7753

Holland Equipment, Ltd.

Norwich, Ontario • Canada
Phone: 519-863-3414
Fax: 519-863-2398

Holland Hitch Western, Ltd.

Surrey, British Columbia • Canada
Phone: 604-574-7491
Fax: 604-574-0244