



LANDING GEAR

SERVICE BULLETIN

Disassembly and Inspection Procedure for Landing Gear LGD700 Series Dual Pin Drop Leg

September 20, 2002

Note: The numbers enclosed in parentheses are located on Page 2, which shows the exploded view of the drop leg.

INTRODUCTION:

This repair procedure describes the method of disassembling model LGD700 to inspect, maintain, and/or disassemble the model LGD700.

DISASSEMBLY:

1. Extend the inner leg assembly until contact with surface or block.
2. Remove rust and burrs from the end of the shaft (*Item 13*), and lubricate to ease removal.
3. Remove the screws (*Item 2*) from the cover (*Item 1*) and gasket (*Item 3*).
4. Remove the groove pin (*Item 5*) from the pinion gear (*Item 9*). There is clearance to drive this pin down into the head.
5. Slide the drive shaft (*Item 13*) out to remove the pinion gear (*Item 9*).
6. Remove the bevel gear (*Item 4*) from the top of the screw. This may require a gear puller.



Failure to support the inner leg assembly (see Step 1) will allow the inner leg to drop out of the outer leg (after Step 7, and could inflict injury to anyone in position of contact.

7. Slide the groove pin (*Item 5*) out, and then remove the washer (*Item 6*).

Note: The groove pin is easier to remove if it is rotated from corner to corner.

8. Inspect groove pin (*Item 5*) and washer (*Item 6*) for damage.

REASSEMBLY:

1. Replace all worn or broken parts.
2. Install the washer (*Item 6*) over the top of the screw. Slide the groove pin (*Item 5*) through the hole in the top of the screw. Corner-to-corner rotation of the hole facilitates this operation.
3. Install the bevel gear (*Item 4*) over the top of the screw and position it so that the slot in the bottom of the gear captures the groove pin (*Item 5*). The top of the screw should be level or slightly higher than the top of the bevel gear.
4. Slide the drive shaft (*Item 13*) through the outside facing bushing, then through the pinion gear (*Item 9*). Make sure pinion gear is oriented toward the inside face of the housing, as shown in the exploded view and the hole in the shaft is facing up.
5. Install the groove pin (*Item 4*) into the drive shaft (*Item 13*) and pinion gear (*Item 9*). Check to see that the gears turn freely.
6. Add a minimum of 1/2 lb. of permanent type grease to the top of the upper housing (*Item 16*). Make sure that grease coats the gears.
7. Install the gasket (*Item 3*), top cover (*Item 1*) and screws (*Item 2*). Do not overtighten the screws.

Dual Pin Individual Parts

ITEM	DESCRIPTION	QTY	PART NUMBER
1	Cover	1	XA-LG0880
2	Screw, Selftap 1/4"-20 x 1/2"	2	XB-ST5-008-11
3	Gasket, Cover	1	XB-LG0893
4	Gear, Bevel	1	XB-LG2027
5	Pin, Groove 1/4" x 1-1/2" Type E	2	XB-GP-014-07
6	Washer, 1.015" ID x 1.75" OD x .13" Thk	1	XB-PW-016-51
7	Bearing, Flange	1	XB-LG1460
8	Bushing, Slip-Fit	2	LG2329
9	Gear, Pinion	1	XB-LG2026
10	Pin, Spring 1/4" x 1-1/2"	1	XB-SP-014-27
11	Screw, Hex-Head 3/8"-16 x 2-1/4" GR 5	1	XB-HHC-50-42
12	Adapter, Crank	1	XB-CP4651-16
13	Shaft, Drive	1	LG2328
14	Nut, Self-Locking 3/8"-16 GR B	1	XB-SLN-012-04
15	Fitting, Grease 1/4"-28 Straight	1	XB-GRF-022-16
16	Housing W/A, Upper	1	LG2392-03
17	Bearing, Thrust	1	XB-BRG-013-70
18	Tube Assy, Retracting & Screw - Dual Pin	1	See Parts Book
19	Decal, Dual-Pin	1	XB-DCL-031-60

U.S. Patent No. 5,423,518

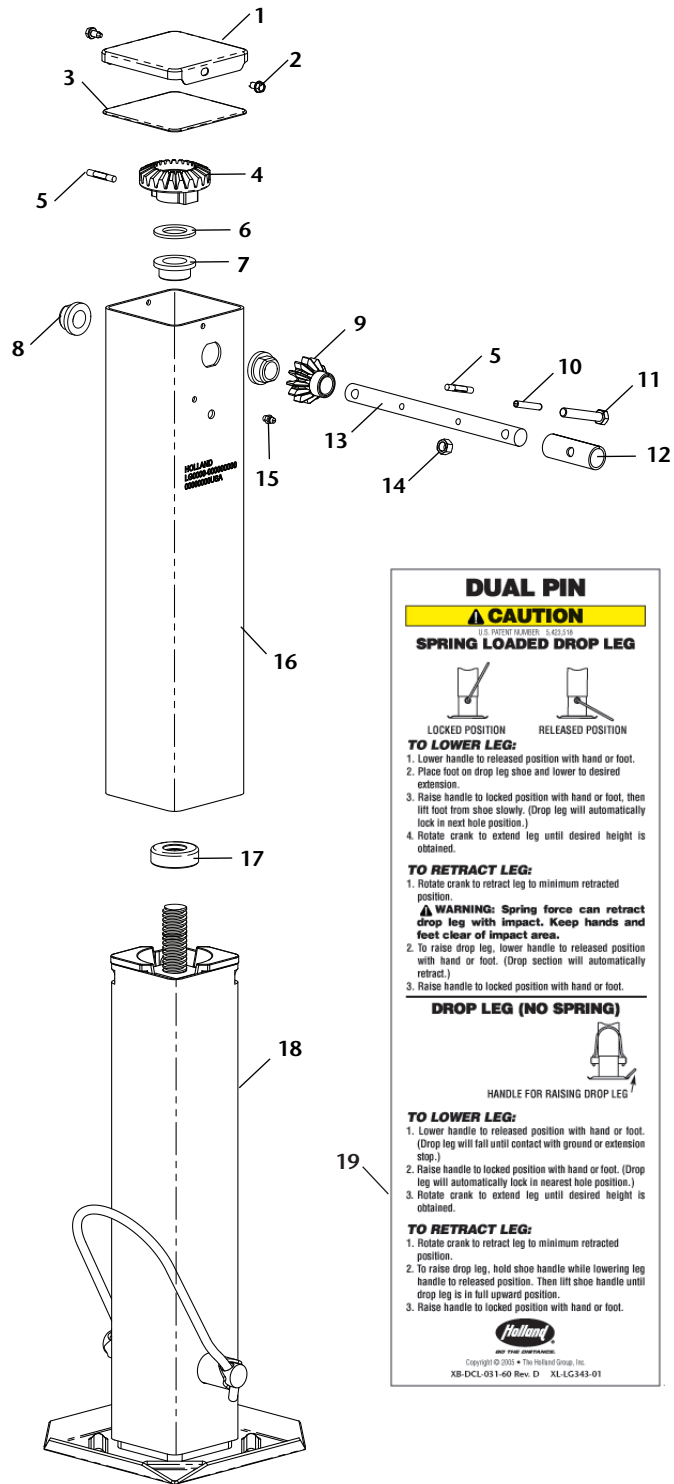

DUAL PIN

CAUTION

U.S. PATENT NUMBER: 5,423,518

SPRING LOADED DROP LEG

LOCKED POSITION

RELEASED POSITION

TO LOWER LEG:

1. Lower handle to released position with hand or foot.
2. Place foot on drop leg shoe and lower to desired extension.
3. Raise handle to locked position with hand or foot, then lift foot from shoe slowly. (Drop leg will automatically lock in next hole position.)
4. Rotate crank to extend leg until desired height is obtained.

TO RETRACT LEG:

1. Rotate crank to retract leg to minimum retracted position.

WARNING: Spring force can retract drop leg with impact. Keep hands and feet clear of impact area.

2. To raise drop leg, lower handle to released position with hand or foot. (Drop section will automatically retract.)
3. Raise handle to locked position with hand or foot.

DROP LEG (NO SPRING)

HANDLE FOR RAISING DROP LEG ↑

TO LOWER LEG:

1. Lower handle to released position with hand or foot. (Drop leg will fall until contact with ground or extension stop.)
2. Raise handle to locked position with hand or foot. (Drop leg will automatically lock in nearest hole position.)
3. Rotate crank to extend leg until desired height is obtained.

TO RETRACT LEG:

1. Rotate crank to retract leg to minimum retracted position.
2. To raise drop leg, hold shoe handle while lowering leg handle to released position. Then lift shoe handle until drop leg is in full upward position.
3. Raise handle to locked position with hand or foot.

Copyright © 2005 - The Holland Group, Inc.
XB-DCL-031-60 Rev. D XL-4G343-01

LOWER LEG HAS NON-SERVICEABLE PARTS



SAF-HOLLAND USA, Inc.
888.396.6501 Fax 800.356.3929

SAF-HOLLAND Canada Limited
519.537.3494 Fax 800.565.7753
Western Canada
604.574.7491 Fax 604.574.0244