

SAF RIGID AXLES FOR TRAILERS



SUPERIOR QUALITY – MANUFACTURED BY
SAF-HOLLAND DO BRASIL

PROVEN DESIGNS – SUPERIOR QUALITY

There is no real substitute for the quality and performance of original SAF Rigid Axles for trailers. Only an original can deliver the reliability and performance needed to succeed in today's tough and competitive environment. That's why SAF Rigid Axles for trailers are the true originals – the exact same axles and components found only on the best SAF-HOLLAND suspension systems offered in the industry today.

ENGINEERING COMPETENCE – ADVANCED TECHNIQUE

SAF Trailer Axles are the product of the shared expertise and experience of SAF-HOLLAND's global engineering network. From extensive laboratory to rigorous real-world testing, SAF axle designs have been proven against the most challenging conditions.

Using state-of-the-art design practices and technologies, SAF-HOLLAND technicians and engineers from around the world build performance, durability and value into every SAF Trailer Axle – now manufactured for you in Brazil.

SAF RIGID AXLES FOR

ABS system available as an option.

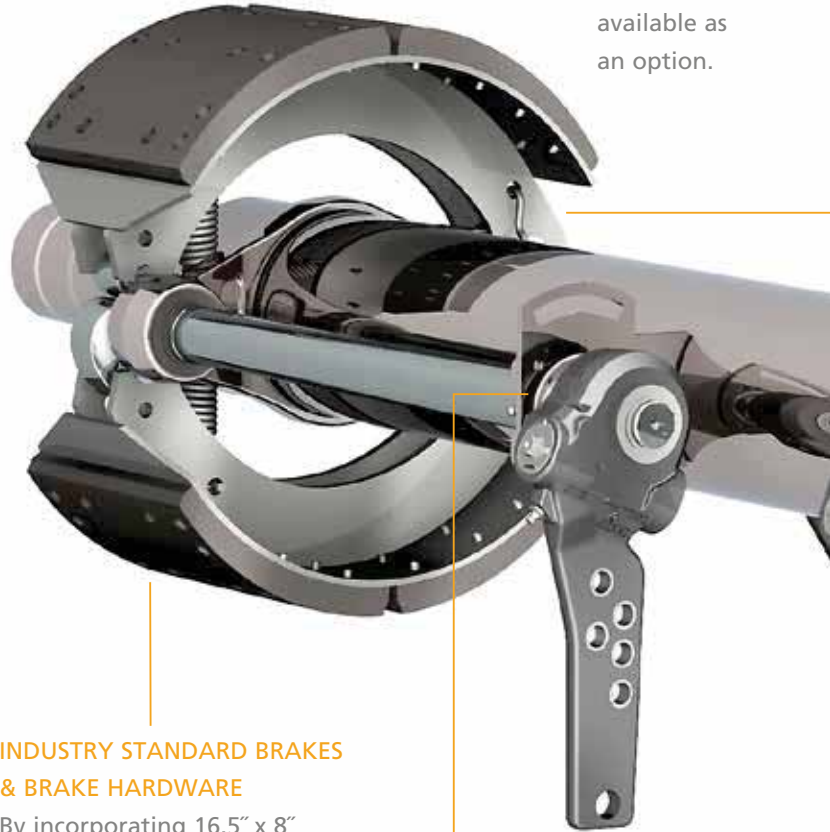

INDUSTRY STANDARD BRAKES & BRAKE HARDWARE

By incorporating 16.5" x 8" brake hardware, replacement parts are economical and easy to find. Original SAF linings provide excellent braking performance to meet a wide range of applications and needs.

TWO-PIECE CAM BUSHINGS

SAF design allows for cam change without hub removal to reduce downtime and lower maintenance costs. The SAF cam design also offers the choice of forward or rear cam application.



SUPERIOR QUALITY – MANUFACTURED IN BRAZIL

SAF-HOLLAND has invested in new axle manufacturing facilities in Brazil, featuring the most advanced manufacturing concepts and expertise currently available to the industry. SAF-HOLLAND leverages FEA modeling and advanced testing to ensure that every axle meets the highest standards for quality, performance and durability.

TRAILERS

WELDED SPIDERS FOR REDUCED WEIGHT AND MAINTENANCE TIME

A robust and solid brake foundation maintains even brake wear, improves braking performance and extends brake life

PRECISION ENGINEERING

Axle tube body is precisely aligned with spindle ends to provide easy and efficient installation, extended tire life and lower cost per mile

PARALLEL SPINDLE DESIGN

90 mm diameter spindle design will match your system and application specifications

127 AND 146 MM ROUND AXLES

Offer universal suspension adaptability and versatility

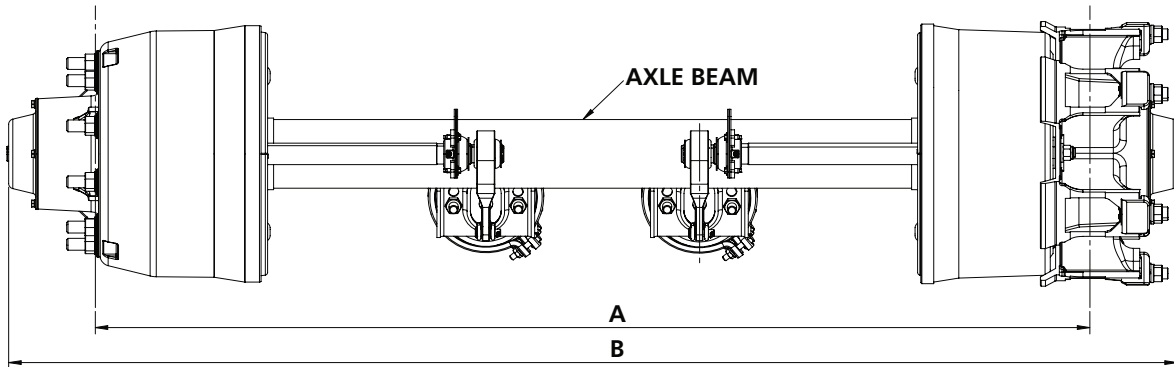

Ø AXLE BEAM mm	"A" TRACK mm	"B" TOTAL mm	CAPACITY (ton)	HUB
127	1842	2157	11	DISC SPOKE 20" SPOKE 22"
127	1942	2257	11 / 16*	
127	2150	2460	11	
127	2324	2633	11 / 16*	
127	2529	2840	11	
146	1842	2157	12	
146	1942	2257	12	
146	2324	2666	12	

* 16 ton for sugar cane, logging applications, etc.



From fifth wheel rebuild kits to suspension bushing repair kits, SAF-HOLLAND Original Parts are the same quality components used in the original component assembly. SAF-HOLLAND Original Parts are tested and designed to provide maximum performance and durability. Will-fits, look-alikes or, worse yet, counterfeit parts will only limit the performance potential and could possibly void SAF-HOLLAND's warranty.

Always be sure to spec SAF-HOLLAND Original Parts when servicing your SAF-HOLLAND product.

XI-TA 10064SL-en-US Rev B · 2013-10-01 · Correções e erratas reservadas ©SAF-HOLLAND, Inc. SAF-HOLLAND, SAF, and SAF-HOLLAND Original Parts logos are trademarks of SAF-HOLLAND S.A., SAF-HOLLAND GmbH, and SAF-HOLLAND, Inc.

HIGH QUALITY COMPONENTS FOR THE COMMERCIAL VEHICLE INDUSTRY



EUROPE · NORTH AMERICA · SOUTH AMERICA · AFRICA · ASIA · AUSTRALIA

SAF-HOLLAND do Brasil

Av. Emílio Marconato, 1000 · Galpão B-16, Chácara Primavera · 13.820-000 Jaguariuna - SP
Tel. + 55 19 3311-1572 · Fax + 55 19 3311-1554 · vendas@safholland.com.br

www.safholland.com.br

