

Replacement Procedure

Trailer Axles

Drum Brake Trailer Axles

S-Cam and Brake Chamber Bracket Replacement

Introduction

This manual provides the information necessary for the replacement of the S-cam bearing and brake chamber brackets on SAF® trailer axles equipped with drum brakes.

NOTE: SAF® Service Manual for Drum Brake Axles, XL-TA100060M-en-US MUST be obtained prior to repairing the axle.

The Service Manual for Drum Brake Axles contains information about removal, installation and verification that the unit can be returned to service which is needed throughout the following procedures. The service manual is available on the internet at www.safholland.us or by contacting Customer Service at 888-396-6501.

When replacement parts are required, use only SAF-HOLLAND® Original Parts. A list of technical support locations that supply SAF-HOLLAND® Original Parts and an Aftermarket Parts Catalog are available on the internet at www.safholland.us or contact Customer Service at 888-396-6501.

Notes, Cautions, and Warnings

Before starting any work on the unit, read and understand all the safety procedures presented in this manual. This manual contains the terms "NOTE", "IMPORTANT", "CAUTION", and "WARNING" followed by important product information. These terms are defined as follows:

NOTE: Includes additional information to enable accurate and easy performance of procedures.

IMPORTANT: Includes additional information that if not followed could lead to hindered product performance.

CAUTION

Used without the safety alert symbol, indicates a potentially hazardous situation which, if not avoided, could result in property damage.

CAUTION

Indicates a potentially hazardous situation which, if not avoided, could result in minor or moderate injury.

WARNING

Indicates a potentially hazardous situation which, if not avoided, could result in death or serious injury.

1. General Safety Instructions

- Read and observe all Warning and Caution hazard alert messages. The alerts provide information that can help prevent serious personal injury, damage to components, or both.

WARNING

Failure to follow the instructions and safety precautions in this manual could result in improper servicing or operation leading to component failure which, if not avoided, could result in death or serious injury.

- All maintenance should be performed by a properly trained technician using proper/special tools, and safe procedures.

NOTE: In the United States, workshop safety requirements are defined by federal and/or state Occupational Safety and Health Act (OSHA). Equivalent laws may exist in other countries. This manual is written based on the assumption that OSHA or other applicable employee safety regulations are followed by the location where work is performed.

- After re-positioning the brake chamber, slack adjuster and/or ABS system as instructed in this manual, ALWAYS consult the manufacturer's manual for proper operation.

IMPORTANT: Key components on each axle system including but not limited to suspension, slack adjuster, brake chambers, bearings, hubs, and drums require information supplied by the original manufacturer of the components to ensure proper and safe operation of the axle system.

WARNING

Failure to follow the original manufacturer's instructions regarding spring brake or air pressure control may allow an uncontrolled release of energy which could result in death or serious injury.

- Service both roadside and curbside of an axle. Worn parts should be replaced in sets. Key components on each axle's braking system, such as friction material, rotors and drums will normally wear over time.
- The wheel contact surfaces between the wheel and hub MUST NOT receive additional paint.

2. Allowable Axle Repairs

SAF® axle repair is limited to the replacement of brake chamber and S-cam brackets on drum brake axles where a brake chamber bracket or an S-cam bracket has been damaged. If any damage, including bending, dents or cracks, is evident on the SAF® axle tube, DO NOT repair the axle. Remove and replace the entire axle.

⚠ WARNING Failure to replace a damaged SAF® axle tube could result in reduced strength in the axle tube which, if not avoided, could result in death or serious injury.

3. Model Identification

Service manuals and repair part information for the SAF® axle and suspension can be located by the suspension model number on the internet at www.safholland.us.

If the serial number tag can not be located or repair and service information obtained from the internet, contact customer service at 888-396-6501.

The model number is located on the serial number tag. The serial number tag location varies by suspension model.

Fixed frame SAF® Air Ride suspensions: Serial Number Tag is located on the roadside frame bracket (**Figure 1**).

Sliding SAF® Air Ride and Leaf Spring Suspensions: Serial Number Tag is located on the rear crossmember (**Figure 2**).

TS Series Mechanical Spring Suspensions: Serial Number Tag is located on the roadside top plate (**Figure 3**).

Figure 1

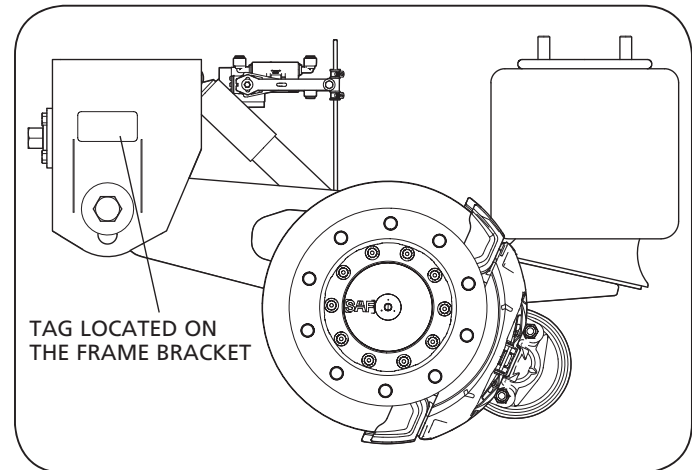

Figure 2

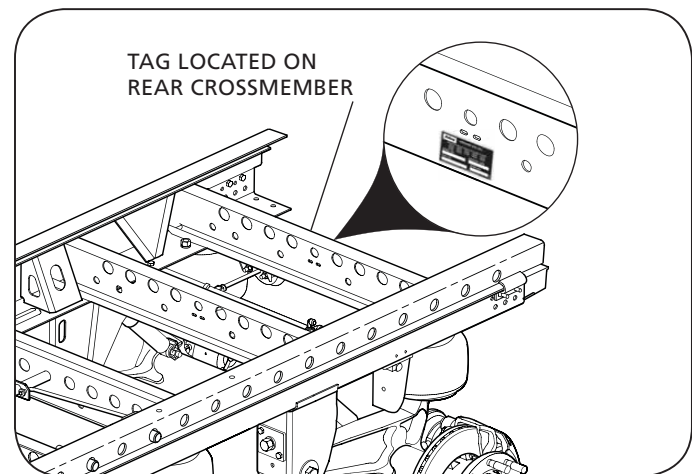
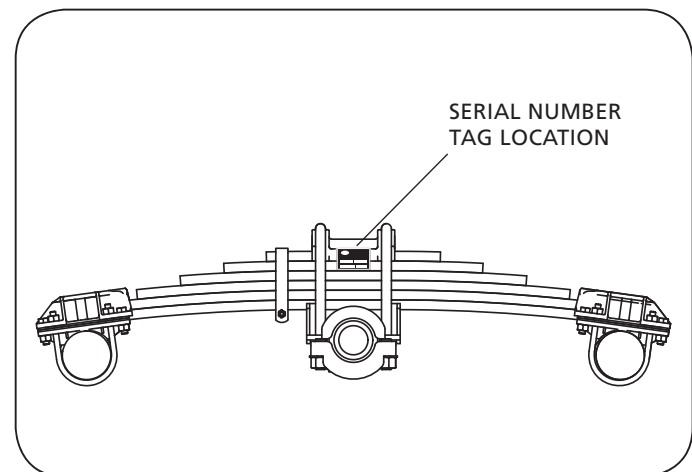

Figure 3



4. Identification Tag

The sample tags shown will help interpret the information on the SAF-HOLLAND, Inc. serial number tag. The tags, which may vary, contain the model number, suspension capacity, part number and serial number. **(Figures 4 and 5)**

Record the tag numbers below for future quick reference.

Model Number: _____

Part Number: _____

Serial Number: _____

Capacity: _____

In Service Date: _____

Figure 4

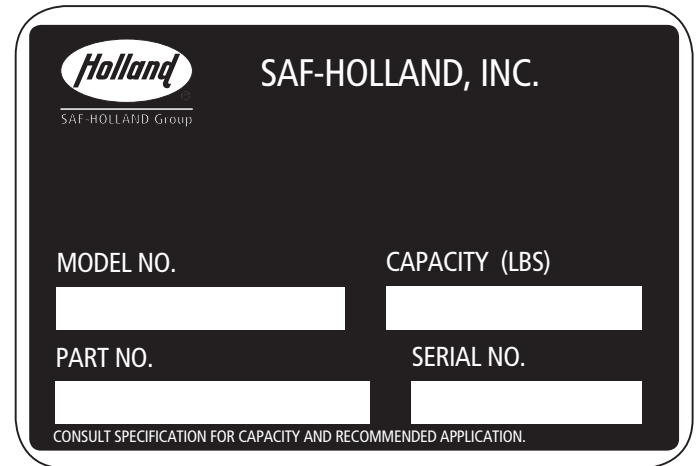
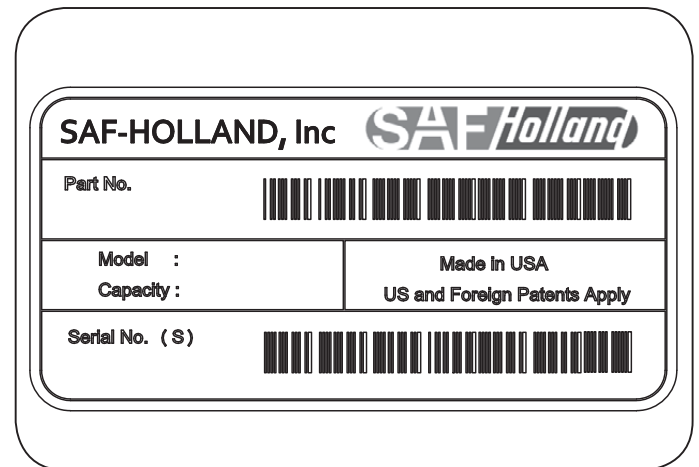

Figure 5



5. Replacement Bracket Welding

5.1 Operator

Installation welding of replacement brackets is to be performed by welders who are certified in accordance with American Welding Society (AWS) D1.1.

5.2 Component Conditions

The axle and replacement bracket(s) must be at least 60° F (15° C) before any weld repair is performed.

The axle and replacement brackets MUST be clean and free from any paint, corrosion, moisture, oil, grease, or debris.

5.3 Weld Parameters

All SAF-HOLLAND® axle repair welds are to be with AWS filler metal specification AWS A5.28, filler metal classification ER-90S-D2.

NOTE: Any substitutions for filler metals from the standard above must comply with the following mechanical properties, at a minimum:

Tensile Strength - 90 KSI (620 Mpa)
 Yield Strength - 78 KSI (540 Mpa)
 Charpy V notch - 20 ft/lbs (27 N•m) @ 0°F (-18°C)
 % Elongation - 17%

The recommended welding gas for gas metal arc welding (GMAW) is 90% Argon / 10% CO2.

5.4 Procedures

Tack welds used in positioning a brake chamber or S-cam bracket are to be located in the center area of the final weld where practical. The tack should be completely fused into the finished weld.

3/8" (10 mm) fillet welds are to be used in the attachment of brake chamber and S-cam brackets.

IMPORTANT: DO NOT break the arc at the end of the weld. Back up all finish welds at least 1/2" (12 mm), or a sufficient amount for the prevention of craters at the end of the weld.

No undercut is allowed on the axle tube.

The maximum depth of undercut on the brake chamber or S-cam bracket shall be no greater than 1/32" (0.8 mm).

IMPORTANT: DO NOT attach the welding ground cable such that wheel bearings are between the ground cable and the area to be welded. This will result in a large electrical current passing through the wheel bearings, potentially damaging them.

WARNING Failure to prevent damaging a wheel bearing by weld current could result in a wheel end failure which, if not avoided, could result in death or serious injury.

6. S-Cam Bracket Replacement

NOTE: SAF® Service Manual for Drum Brake Axles, XL-TA100060M-en-US and appropriate suspension model manuals MUST be obtained prior to repairing axle.

1. If possible, remove the axle from the trailer. Refer to the appropriate suspension model manual for proper procedures.
2. Remove the brake adjuster adjacent to the damaged S-cam bracket, refer to SAF® Service Manual for Drum Brake Axles, XL-TA100060M-en-US.
3. Detach the bushing assembly from the damaged S-cam bracket and S-cam, refer to SAF® Service Manual for Drum Brake Axles, XL-TA100060M-en-US.
4. Using a straight edge and a permanent marker or scribe, mark the bracket location. Be careful when removing the bracket to avoid removing the location marks (**Figure 7**).
5. Remove the damaged S-cam bracket.
 - Minimize the heat introduced into the axle tube by cutting the bracket off as quickly as possible, at a distance of 1/4" (6 mm) to 1/2" (12 mm) from the axle tube (**Figure 8a**).

⚠ WARNING Failure to minimize the heat introduced into the axle tube or damaging the surface of the SAF® axle tube can reduce the strength of the axle, potentially causing axle fracture which, if not avoided, could result in death or serious injury.

- When removing the damaged S-cam bracket, be careful not to cut or grind below the surface of the SAF® axle tube.
6. Being careful not to remove the location marks, grind away the remaining portion of the bracket (**Figure 8b**).
 7. Using a straight edge and a permanent marker or scribe, draw lines to connect the previously made location marks from Step 4 (**Figure 9**).

Figure 7



Figure 8a and 8b



Figure 9



- Attach the bushing assembly to the new S-cam bracket and slide the bracket and bushing assembly onto the S-cam (**Figure 10**).

IMPORTANT: DO NOT use a damaged bushing assembly, replace damaged parts.

CAUTION Failure to replace a damage bushing assembly could result in reduced brake performance which, if not avoided, could result in component damage.

- Using the bracket location marks from Step 7, position the bracket tight to axle tube (**Figure 11**).
- Tack weld the center of the bracket to the axle tube with a 1/4" (6 mm) tack weld on both sides of the bracket (**Figure 12**).
- Remove the bushing assembly.

Figure 10



Figure 11



Figure 12



12. Measure and mark the axle tube 1/8" (3 mm) from each end of the S-cam bracket (**Figure 13**).
13. Verify the S-cam bracket is square to the axle tube.
14. Make sure both the axle tube and the S-cam bracket are clean and free from all moisture, scale, grease, oil and weld slag from the tack welds.
15. Weld both sides of the bracket with a 3/8" (10 mm) fillet weld, refer to Welding Standards in Section 5. Make sure that both welds stop at least 1/8" (3 mm) from the edge of the bracket, as marked in Step 12 (**Figure 14**).
16. Clean and paint/undercoat the welded area and any adjacent area where paint was removed to facilitate bracket replacement.
17. Re-install the bushing assembly. Torque the bolts to 25-30 ft.-lbs. (33-40 N•m).
18. Re-attach the brake adjuster. Refer to SAF® Service Manual for Drum Brake Axles, XL-TA100060M-en-US or as recommended by the brake adjuster manufacturer.
19. Re-install the axle per the instructions included in the appropriate suspension model's manual.

7. Brake Chamber Bracket Replacement

1. If possible, remove the axle from the trailer. Refer to the appropriate suspension model manual.
2. Remove the brake chamber from the damaged bracket using the brake chamber manufacturer's instructions.
3. Using a straight edge and a permanent marker or scribe, mark the bracket location. Be careful when removing the bracket to avoid removing the location marks (**Figure 15**).

Figure 13



Figure 14



Figure 15



4. Remove the damaged brake chamber bracket.
 - Minimize the heat introduced into the axle tube by cutting the bracket off as quickly as possible, at a distance of 1/4" (6 mm) to 1/2" (12 mm) from the axle tube (**Figure 16**).

⚠ WARNING Failure to minimize the heat introduced into the axle tube or damaging the surface of the SAF® axle tube can reduce the strength of the axle, potentially causing axle fracture which, if not avoided, could result in death or serious injury.

- When removing the damaged S-cam bracket, be careful not to cut or grind below the surface of the SAF® axle tube.
5. Being careful not to remove the location marks, grind away the remaining portion of the bracket (**Figure 17**).
 6. Using a straight edge and a permanent marker or scribe, draw lines to connect the previously made location marks from Step 3 (**Figure 18**).

Figure 16



Figure 17



Figure 18



8. Place a new brake chamber bracket on the axle in alignment with the location marks (**Figure 19**).
9. Make sure both the bracket and axle tube are clean and free from all moisture, scale, grease, and oil.
10. Tack weld the center of the bracket to the axle tube with a 1/4" (6 mm) tack weld on the outsides of the two legs (**Figure 20**).
11. Verify that the brake chamber bracket is aligned with the brake chamber bracket on the opposite side by using a long straight edge. If the brackets are not in alignment, remove the tack weld, re-position the bracket and re-tack weld.
12. Place a mark 1/8" (3 mm) in from the end of the brake chamber bracket on both the inside and outside of both legs (**Figure 21**).

Figure 19



Figure 20



Figure 21



13. Weld the brake chamber bracket with a 3/8" (10 mm) fillet weld on the both the inside and outside of both legs, refer to Welding Standards in Section 5. Make sure the welds stop at least 1/8" (3 mm) from the edge of the bracket, at the mark created in Step 11 (**Figure 22**).
14. Clean and paint/undercoat the welded area and any adjacent area where paint was removed to facilitate bracket replacement.
15. Re-install the brake chamber according to the brake chamber manufacturer's instructions.
16. Re-install the brake adjuster, refer to SAF® Service Manual for Drum Brake Axles, XL-TA100060M-en-US or as recommended by the brake adjuster manufacturer.
17. Re-install the axle in accordance with the instructions included in the appropriate suspension model's manual.

Figure 22





From fifth wheel rebuild kits to suspension bushing repair kits, SAF-HOLLAND Original Parts are the same quality components used in the original component assembly.

SAF-HOLLAND Original Parts are tested and designed to provide maximum performance and durability. Will-fits, look-alikes or, worse yet, counterfeit parts will only limit the performance potential and could possibly void SAF-HOLLAND's warranty. Always be sure to spec

SAF-HOLLAND Original Parts when servicing your SAF-HOLLAND product.

SAF-HOLLAND USA • 888.396.6501 • Fax 800.356.3929

www.safholland.us

SAF-HOLLAND CANADA • 519.537.3494 • Fax 800.565.7753

WESTERN CANADA • 604.574.7491 • Fax 604.574.0244

www.safholland.ca

SAF-HOLLAND MEXICO • 52.55.5362.8743 • Fax 52.55.5362.8743

www.safholland.com.mx

info@safholland.com