

SAF ● SC5 WHEEL ENDS

SAF SC5 Dressed Drum Brake Wheel End Package for CBX and ULX Series Trailer Suspension and Axle Systems with 5 Year Parts and Labor Warranty

SAF SC5 Wheel Ends Make Good System Sense.

Complete your SAF Suspension/Axle system with SAF SC5 wheel ends. No need to be a wheel end expert, let SAF-HOLLAND expertise go to work for you. Our thorough assembly processes eliminate the hassles and ensures accurate installation every time.

SC5 Package Variations:

- Spindle Types: Parallel or Tapered
- Lubrication: Synthetic Oil or Synthetic Semi-Fluid Grease
- Hubs & Drums: Standard or Lightweight
- Short or Long Studs
- Optional SAF TIRE PILOT PLUS™ tire pressure management system or MTIS (PSI) axle prep

The SAF SC5 wheel end package is offered on all CBX and ULX suspensions.



CBX Series

ULX40

The SC5 Dressed Drum Brake package only offered on the 16.5" x 7" brake size

SC5 DRESSED DRUM BRAKE WHEEL ENDS FOR CBX AND ULX TRAILER SUSPENSION/AXLE SYSTEMS

Spindle

- Available in parallel or taper spindle
- Wide based tire compatible with 2" offset rims (Parallel spindle only)
- One step precision machining to precisely align bearings and seals

Premium Axle Spindle Nut

- Safer service and easier installation with a single-piece nut system
- Specialized locking system that prevents inadvertent back-offs when engaged and easily disengaged for simple removal

Aluminum Hub Caps

- Defends against contamination ingress in tough environments
- Both Original & Tire Pilot Plus (TPP)

Premium Seal

- Long lasting seal with Teflon lay-down lip that protects against extreme temperatures and corrosive chemicals
- Leak resistant to help prevent contamination

Field Proven Lube System

- Specially Formulated to withstand extreme cold and heat
- Superb performance with reduced friction and wear

Hubs

- Easy and accurate lube ports in tough, cast steel hub as standard: lightweight (ADI) hub option available

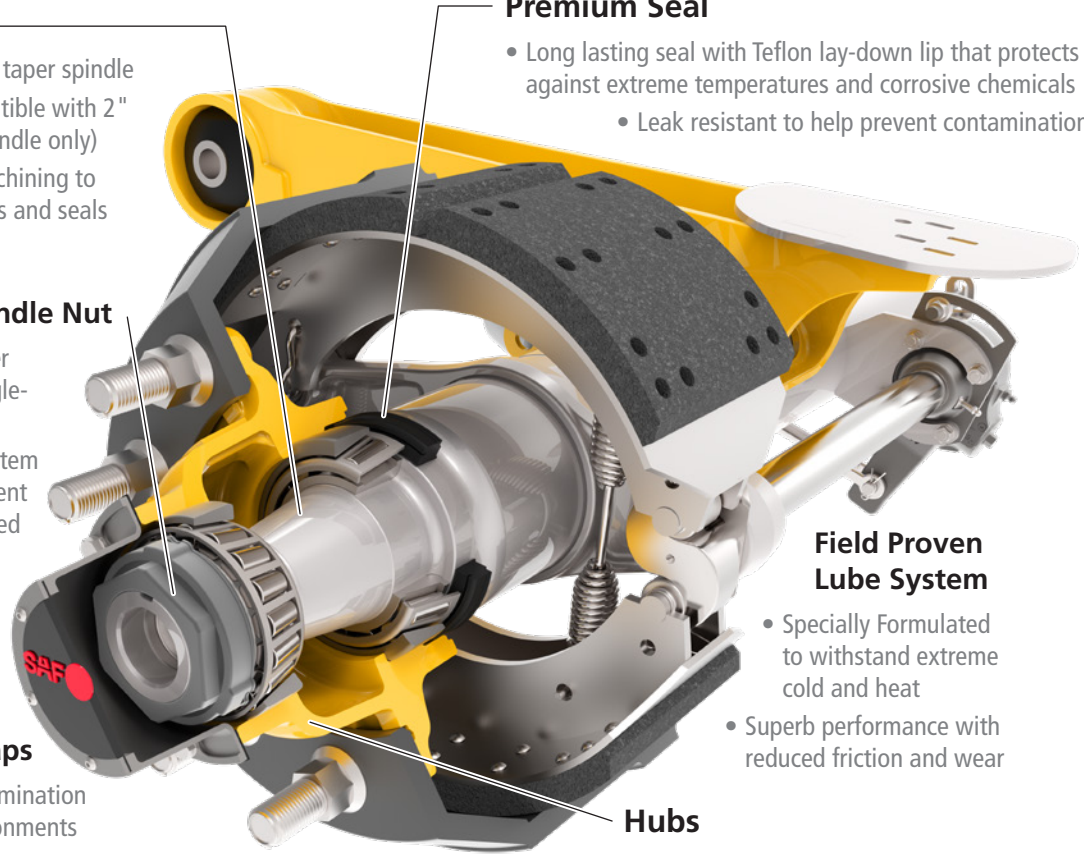

COMPONENT SPECIFICATIONS

1. Hub Caps – Variable per Lubrication and ATIS choice
2. Spindle Nut – Premium Nut - For Accurate Installation
3. Hub/Drum Packages – Standard and Lightweight
4. Standard Package – Steel Hub and Cast Iron Drum
5. Lightweight Package – ADI Hub with Lightweight Drum
6. Lubrication – Synthetic Oil or Synthetic Semi-Fluid Grease
7. Wheel Studs – Long or Short Available
8. 28 Spline S-Camshafts – Hardened Steel: Cam Enclosures Optional
9. Automatic Slack Adjuster – Industry Standard 5.5"

NOTE: The SAF SC5 wheel end package includes: hubs/drums, bearings, lubrication, seals, hub caps, brake actuators, slack adjusters, and spindle nuts.

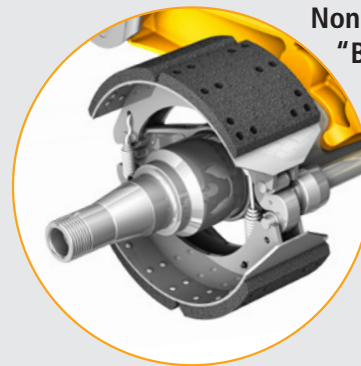

Non-Dressed or "Braked" Wheel Ends Available in the Following Brake Sizes:

- 16.5" x 7"
- 16.5" x 8.62"
- 12.25" x 7.5"

PRODUCT TECHNICAL SPECIFICATIONS

SC5 WHEEL END PACKAGES

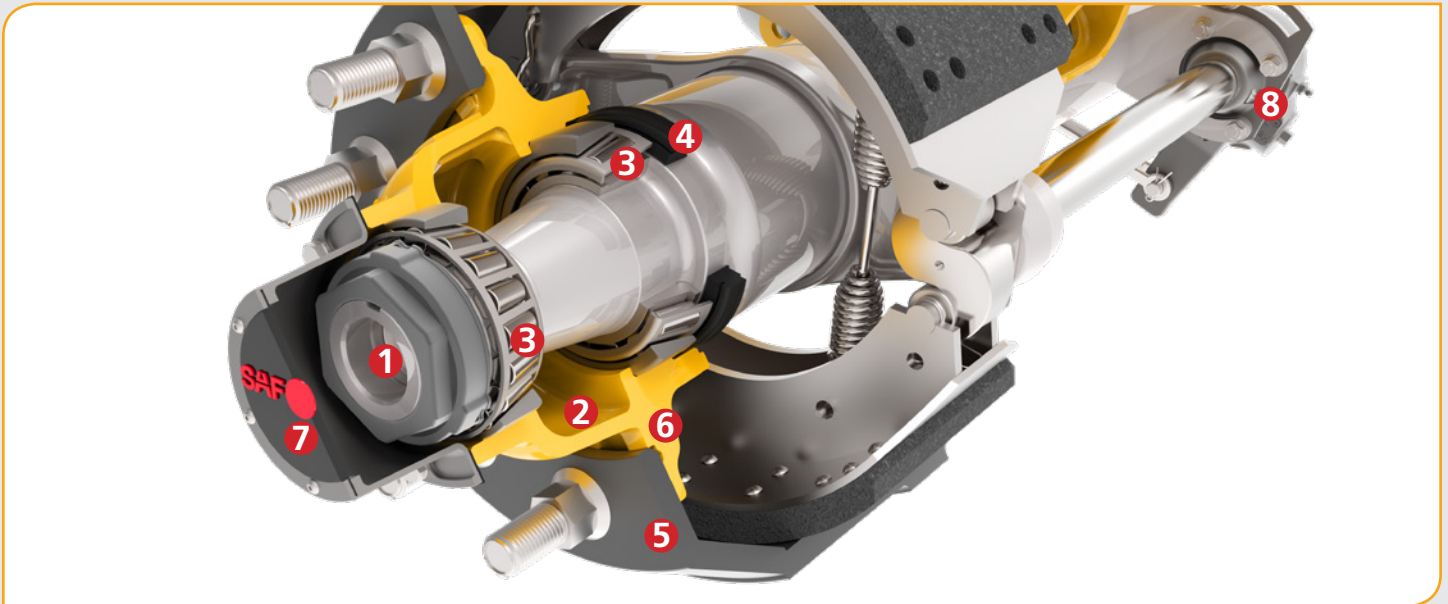

1 SPINDLE

TYPE	SPECIFICATION	MAXIMUM WHEEL OFFSET	PREMIUM NUT
Taper	Industry std.	0"	One Piece to Prevent Back-Off
Parallel	Industry std.	2"	

2 LUBRICATION

TYPE	SPECIFICATION	GRADE
Oil	SAE 75W/90	Synthetic Premium
Grease	NLG100/0	

3 BEARING

TYPE	SPECIFICATION	HD-INNER	HD-OUTER
Taper	Manufactured to Industry Standards	HM218248	HM212049
Parallel		HM518445	

4 OIL SEAL - INTEGRAL DESIGN

High Performance Double Sealing Lip
Self-Lubricating Thrust Pad
High Temp Resistance

5 BRAKE DRUM

TYPE	MATERIAL	WEIGHT	PER AXLE RATING
Cast	Cast Iron	-	23,000 lbs.
Centrifuse		15% Lighter	

6 HUB

TYPE	MATERIAL	LUBRICATION	STUDS	GAWR
Taper	Cast Steel/ Ductile Iron	Oil or Grease	Long/Short	25,000 lbs.
Parallel				

7 HUB CAPS

Lightweight Aluminium Cast

8 SLACK ADJUSTER S-ABA

High Alloy Steel Gears
Heat-Treated Housing
Centralized Clutch
Arm Length 5.5"
Grease Fitting

BRAKE ACTUATOR (NOT SHOWN)

TYPE	ROD	ROD w/ CLEVIS	STROKE
Horizontal Mount	5.8"	7.0"	2.5"

DUST SHIELD - OPTIONAL (NOT SHOWN)

Clamp on Style

THE SAF SC5 WHEEL END PACKAGE CAN BE SPECIFIED WITH ANY OF THESE SAF AIR AND SPRING RIDE SUSPENSIONS

SLIDING VAN/REEFER SUSPENSIONS

AeroBeam™
CBX40
 Slider Air Suspension/
 Axle Systems
 40,000 lb. Capacity

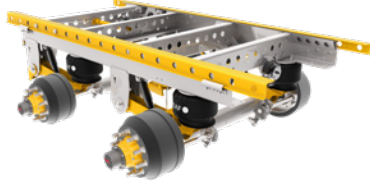

CBX46 & CBX50
 Slider Air Suspension/
 Axle Systems
 46,000 lb. & 50,000 lb. Capacity

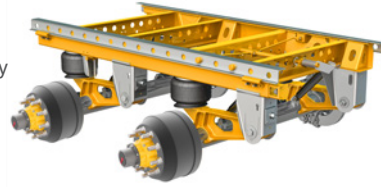

CBX69
 Tridem Slider Air
 Suspension/Axle Systems
 69,000 lb. Capacity



ULX40
 Slider Spring Suspension/
 Axle System
 40,000 lb. Capacity

FIXED FRAME SPECIALTY SUSPENSIONS

AeroBeam™
CBX23
 Air Suspension/Axle System
 23,000 lb. Capacity

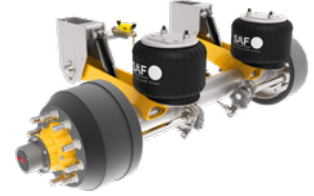

CBX23 & CBX25
 Air Suspension/Axle System
 23,000 lb. & 25,000 lb. Capacity



CBXu Series
 Air Suspension/
 Underslung Axle System
 23,000 lb. & 25,000 lb. Capacity



CBXy Series
 Yoke Mount
 Air Suspension/Axle System
 25,000 lb. Capacity

XL-TA20033SL-en-US Rev B · 2019-07-22 · Amendments and errors reserved ©SAF-HOLLAND, Inc. SAF-HOLLAND, SAF-HOLLAND, NEWAY, KIL, CORPCO, V.ORLANDI, YORK, AeroBeam, are trademarks of SAF-HOLLAND S.A., SAF-HOLLAND GmbH, and SAF-HOLLAND, Inc.

safholland.us

safholland.com.mx

safholland.ca

SAF-HOLLAND USA, Inc.
 800.876.3929

SAF-HOLLAND MEXICO
 52.55.5456.8641

SAF-HOLLAND Canada Limited
 519.537.3494
 Western Canada
 604.574.7491

